

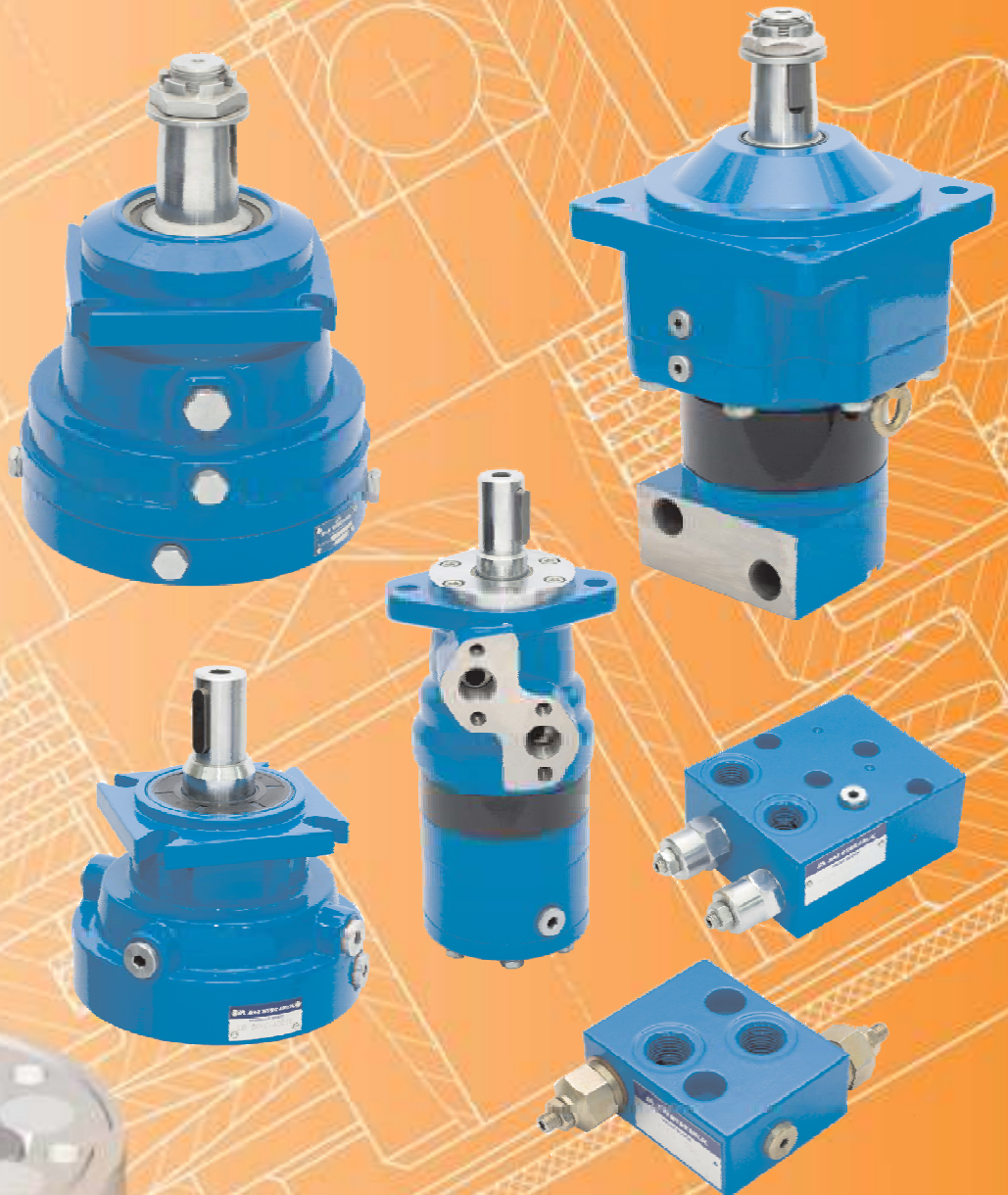

M+S HYDRAULIC

HYDRAULIC BRAKES MOTOR-BRAKES & VALVE BLOCKS



ACCESSORIES and MOTOR-BRAKES

CONTENTS

	Page
● Hydraulic Disc Brake for MP, MR and MS type LB/288	3
● Hydraulic Disc Brake for MSS type LBS/289(290) and MSV type LBV/289(290)	6
● Hydraulic Disc Brake for MTS type LBS/314(315) and MTV type LBV/314(315)	10
● Hydraulic Disc Brake for MVS type LBS/313 and type LBS/316	14
● Hydraulic Disc Brake type B...R	18
● Hydraulic Disc Brake type B...T	19
● Hydraulic Disc Brake type B-130K.....	20
● Hydraulic Motor-brakes type B/MR	21
● Hydraulic Motor-Brakes type MT/B	27
● Hydraulic Motor-brakes type MTM/B	31
● Hydraulic Motor-brakes type SW	37
● Hydraulic Motor-brakes type TW	40
● Overcenter Valves with Brake Control	43
● Switch Valves	51
● Crossover Relief Valves	53
● Cross Port Relief Valves	61
● Motor-Brakes Special Features	64
● Application Calculation	65

HYDRAULIC DISC BRAKES LB, LBS, LBV- Wet



APPLICATION

- » Heavy Duty machinery
- » Wheel drives
- » Material handling
- » Mining
- » Agricultural machines
- » Conveyors
- » Door openers and swing drives etc.



GENERAL

Fluid type	Mineral based- HLP(DIN 51524) or HM(ISO 6743/4)
Temperature range, °C [°F]	-40÷140 [-40÷284]
Viscosity range, mm²/s	20÷75 [98÷347]
Filtration	ISO code 20/16 (nominal filtration of 25 microns)
Maintenance	Changed after the first 50-100 h, then after every 500-1500 h.

CONTENTS

Hydraulic Disc Brake for MP, MR and MS Motors type LB/288	4÷5
Hydraulic Disc Brake for MSS and MSV type LBS(V)/289	6
Hydraulic Disc Brake for MSS and MSV type LBS(V)/290	7
Output Shafts for LBS(LBV)/289, 290	8
Specification data for LBS(LBV)/289, 290	8
Load curve for LBS(LBV)/289, 290	8
Internal Spline data for .../289,290 and .../314,315.....	9
Order code for LB/288,LBS(LBV)/289, 290	9
Hydraulic Disc Brake for MTS and MTV type LBS(LBV)/314	10
Hydraulic Disc Brake for MTS and MTV type LBS(LBV)/315	11
Specification data for LBS(LBV)/314, 315	12
Load curve for LBS(LBV)/314, 315	12
Output Shafts for LBS(LBV)/314, 315	13
Order code for LBS(LBV)/314, 315	13
Hydraulic Disc Brake for MVS type LBS/313	14
Load curve for LBS/313	14
Hydraulic Disc Brake for MVS type LBS/316	15
Load curve for LBS/316	15
Specification data for LBS/313, 316.....	16
Output Shafts for LBS/313, 316	16
Internal Spline data for LBS/313, 316	17
Order code for LBS/313, 316	17

LB, LBS

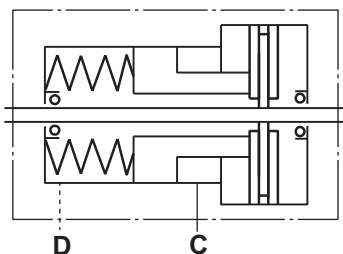

LBV

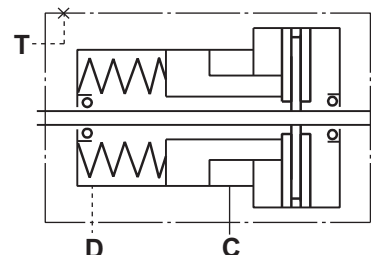

HYDRAULIC DISC BRAKE FOR FLANGE ATTACHMENT TO MP, MR AND MS HYDRAULIC MOTORS

TYPE LB/288

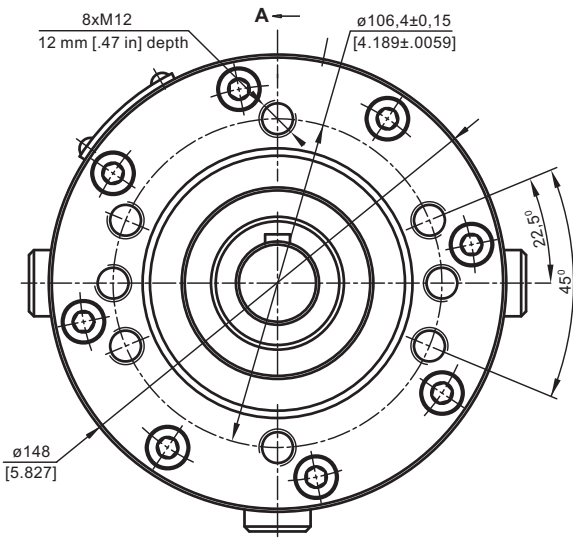
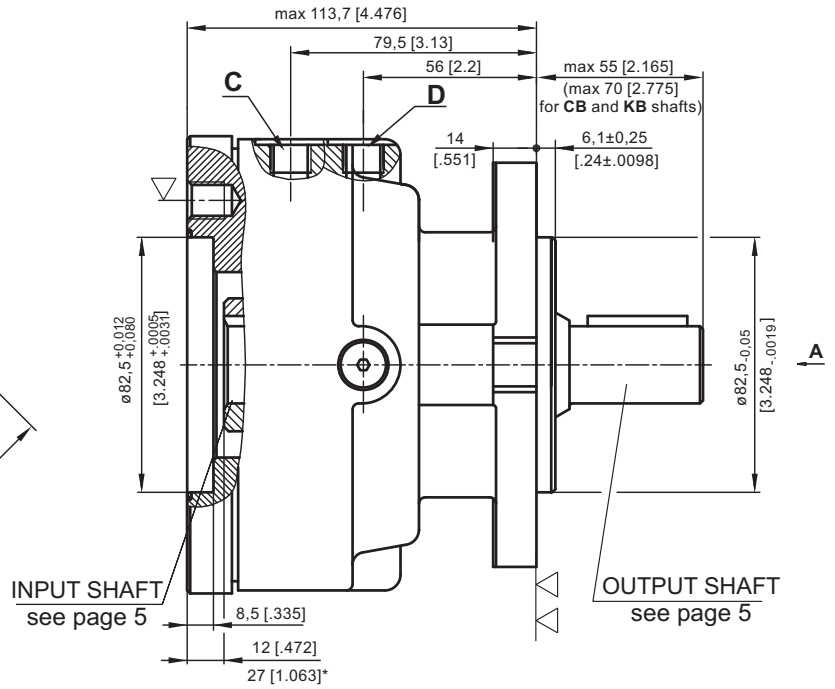
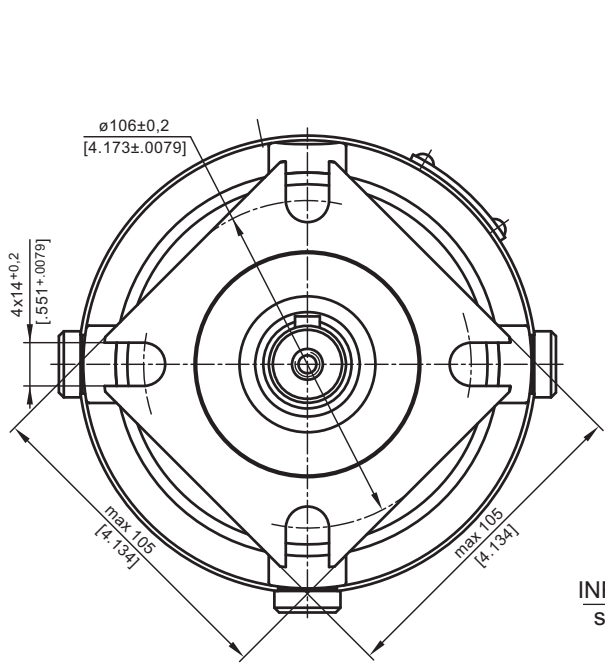

- ▽ - Place for attachment (tightening torque for screw M12x30 - 8.8 DIN 912 - 7 daNm [620 lb-in])
- ▽▽ - Place for attachment
- C:** Brake release Port - G $\frac{1}{4}$, 9 mm [0.35 in] depth
- D:** Drainage tap - G $\frac{1}{4}$, 9 mm [0.35 in] depth
- * - For Input Shaft Hole Versions **SH** and **SB**.

LOAD CURVE

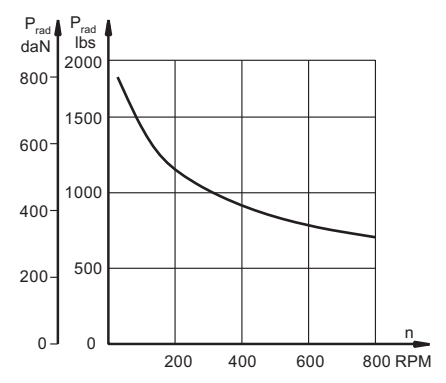

SPECIFICATION DATA

Description LB/288...	7	14	21	32	43	63
*Min. Static Torque, daNm [lb-in]	6-8 [531-708]	13-15 [1150-1327]	20-22 [1770-1947]	31-34 [2743-3009]	41-45 [3628-3982]	61-64 [5399-5665]
Opening Pressure, min bar [PSI]	4-5 [58-73]	8-9 [116-130]	12-13 [174-188]	18-20 [260-290]	24-26 [348-377]	38-39 [550-565]
max	300 [4350]					
Min. oil quantity for brake releasing, cm 3 [in 3]	7 - 8 [0.427 - 0.488]					
Oil volume cm 3 [in 3]	50 - 120 [3.5 - 7.35]					
Max. Pressure in drain space, bar [PSI]	0,5 [7.25]					
Weight, kg [lb]	9 [19.8]					

*Static torque is obtained at working pressure - 0 bar [0 PSI].

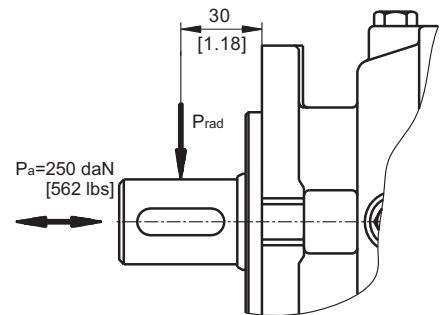

INPUT SHAFT HOLES

C

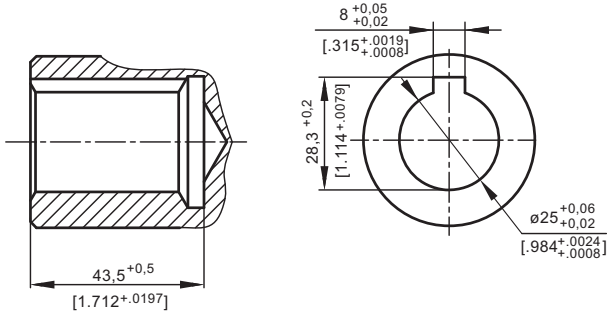

CO

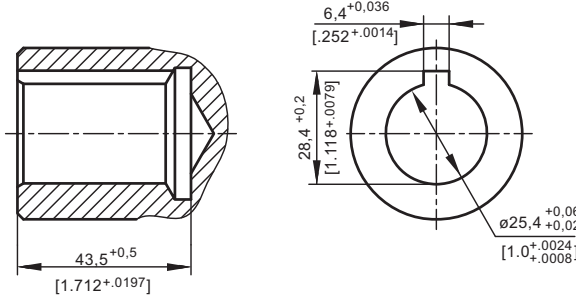

SH

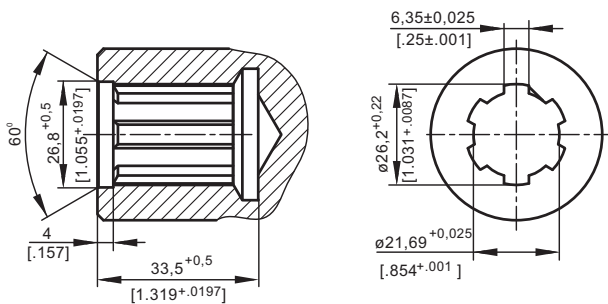

SB

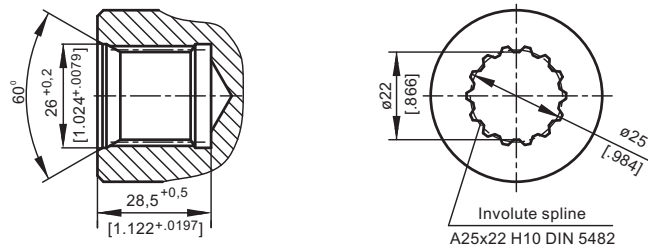

CB

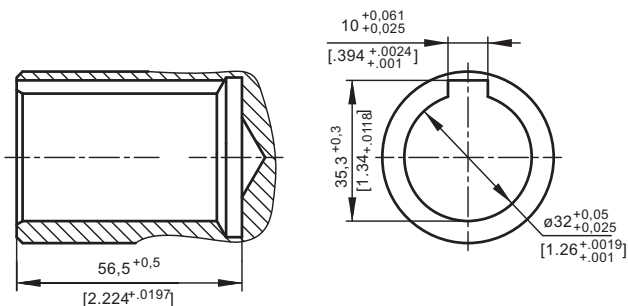

OUTPUT SHAFT EXTENSIONS

C - ø25 straight, Parallel key A8x7x32 DIN 6885
Max. Torque 34 daNm [3010 lb-in]

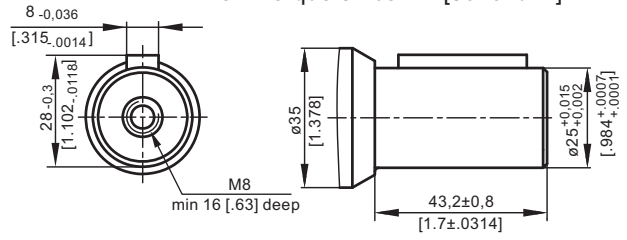

CO - ø1" straight, Parallel key 1/4"x1/4"x1/4" BS46
Max. Torque 34 daNm [3010 lb-in]

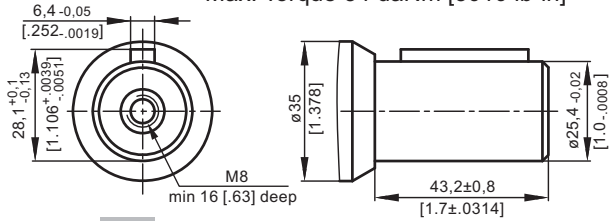

SH - splined, BS 2059 (SAE 6B)
Max. Torque 40 daNm [3540 lb-in]

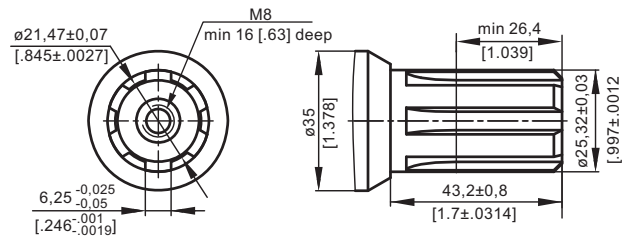

SA - splined, B25x22h9 DIN 5482
Max. Torque 40 daNm [3540 lb-in]

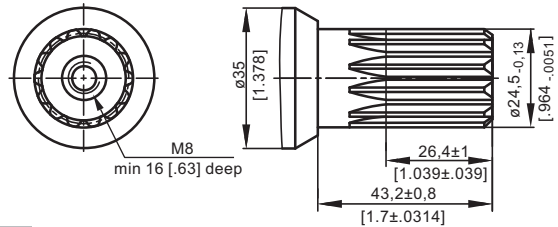

CB - ø32 straight, Parallel key A10x8x45 DIN 6885
Max. Torque 77 daNm [6815 lb-in]

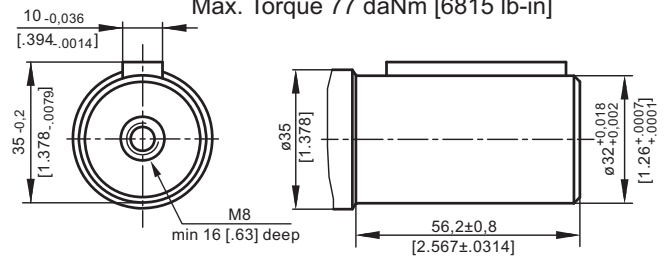

KB - tapered 1:10, Parallel key B6x6x20 DIN 6885
Max. Torque 95 daNm [8400 lb-in]

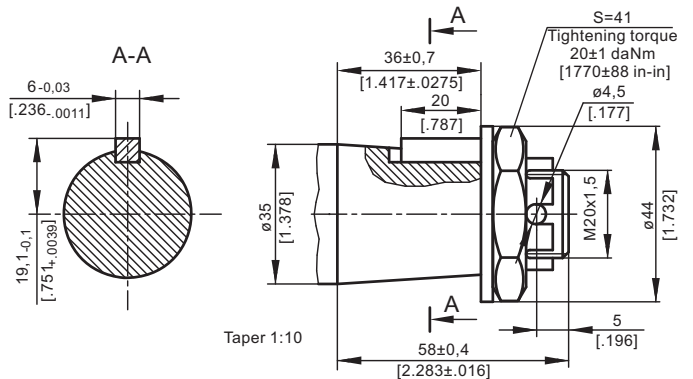

**HYDRAULIC DISC BRAKE FOR FLANGE ATTACHMENT
TO MSS AND MSV HYDRAULIC MOTORS**

TYPE LBS/289

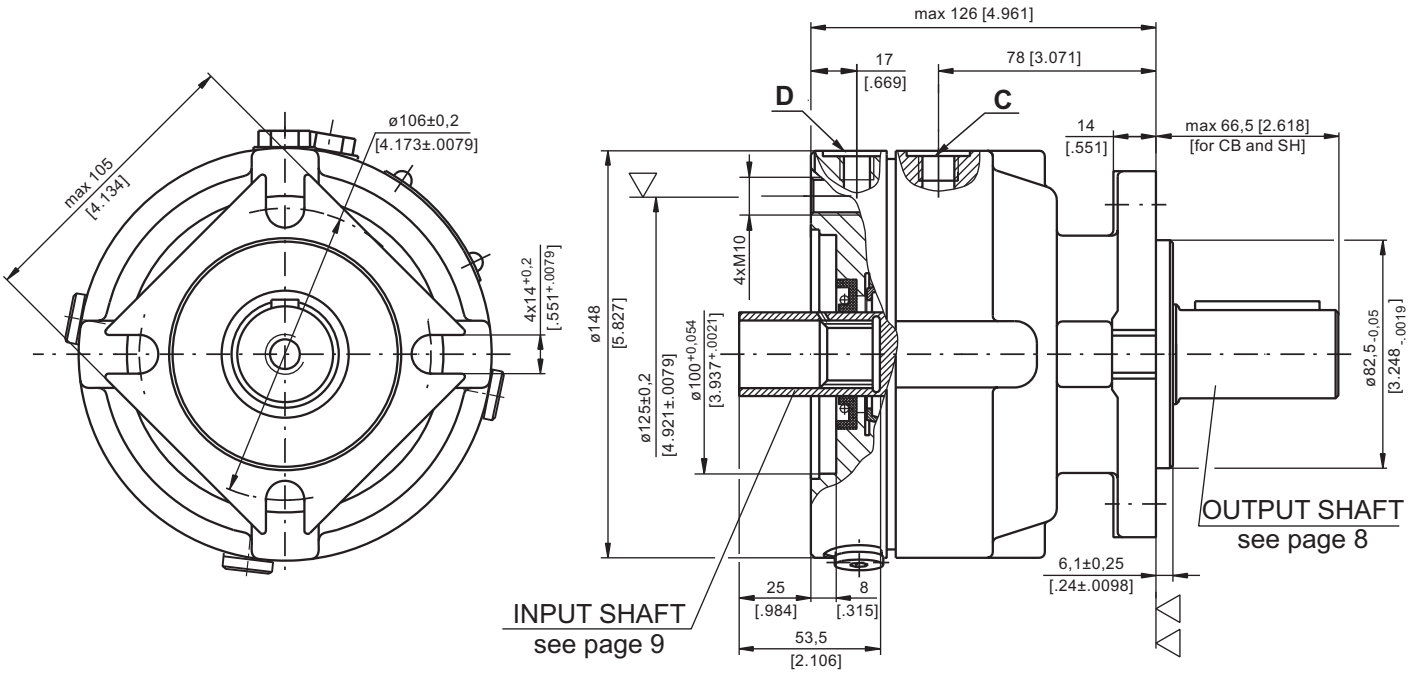

- ▽ - Place for attachment:
LBS - tightening torque for screw M10x35 - 8.8 DIN 912 - 5 daNm [440 lb-in]
LBV - tightening torque for screw M10xL - 12.9 DIN 931 - 6⁺¹ daNm [530⁺⁹⁰ lb-in]

▽▽ - Place for attachment



mm [in]

- C:** Brake release Port - G $\frac{1}{4}$, 9 mm [.35 in] depth
- D:** Drain plug for the Brake - G $\frac{1}{4}$, 9 mm [.35 in] depth
- T:** Drain plug for the Motor - G $\frac{1}{4}$, 9 mm [.35 in] depth

TYPE LBV/289

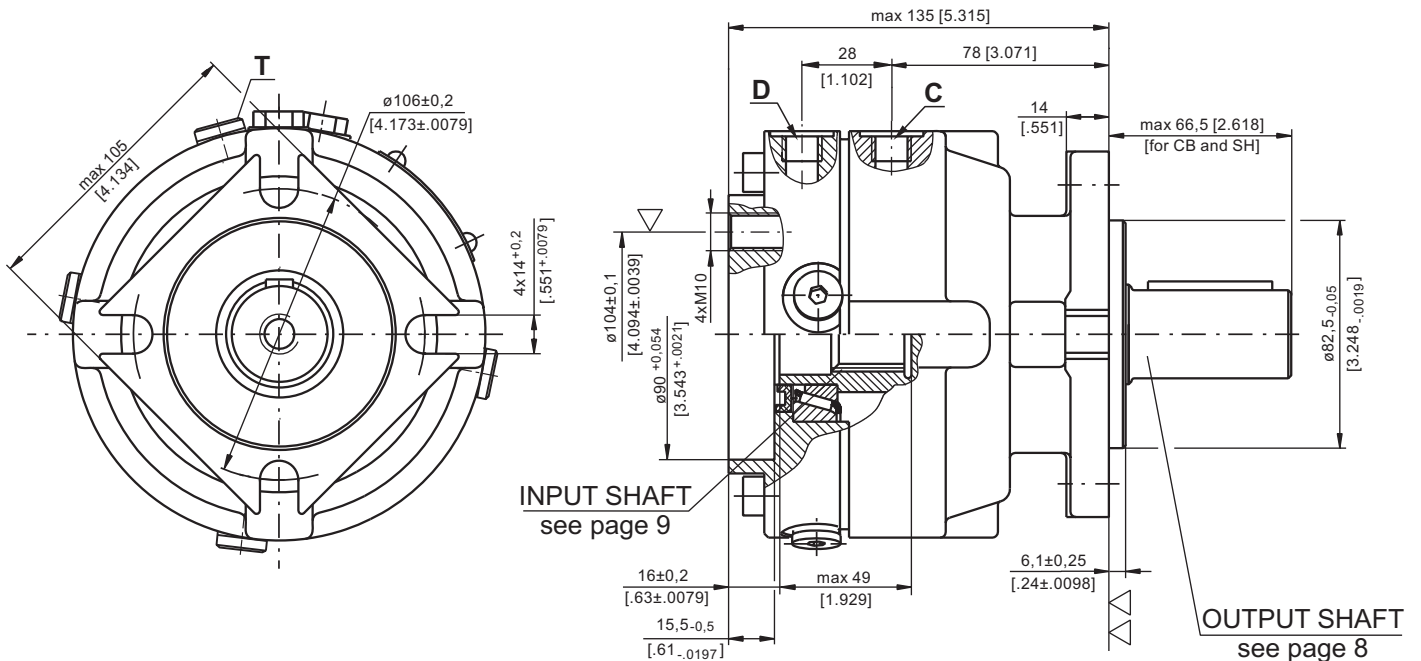

HYDRAULIC DISC BRAKE FOR FLANGE ATTACHMENT TO MSS AND MSV HYDRAULIC MOTORS

TYPE LBS/290

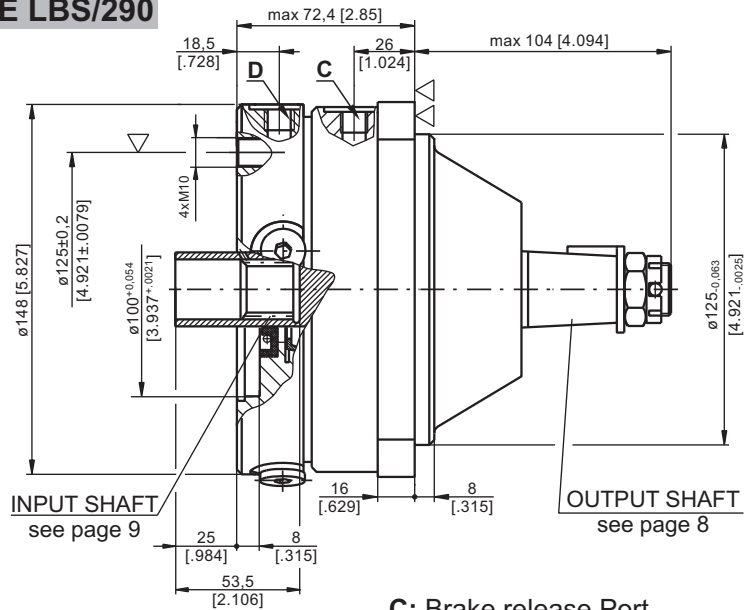
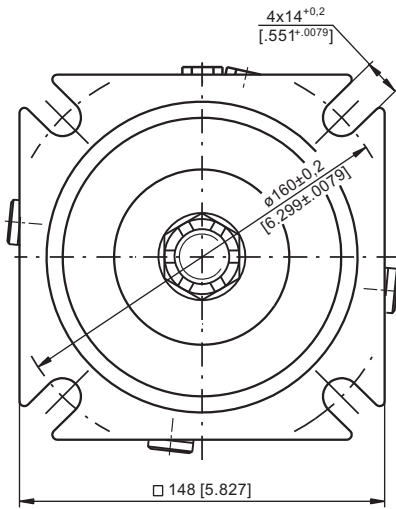

- ▽ - Place for attachment:
 LBS - tightening torque for screw M10x35 - 8.8 DIN 912 - 5 daNm [440 lb-in]
 LBV - tightening torque for screw M10xL - 12.9 DIN 931 - 6⁺ daNm [530⁹⁰ lb-in]
- ▽▽ - Place for attachment

- C:** Brake release Port
 - G¹/₄, 9 mm [.35 in] depth
- D:** Drain plug for the Brake
 - G¹/₄, 9 mm [.35 in] depth
- T:** Drain plug for the Motor
 - G¹/₄, 9 mm [.35 in] depth

TYPE LBV/290

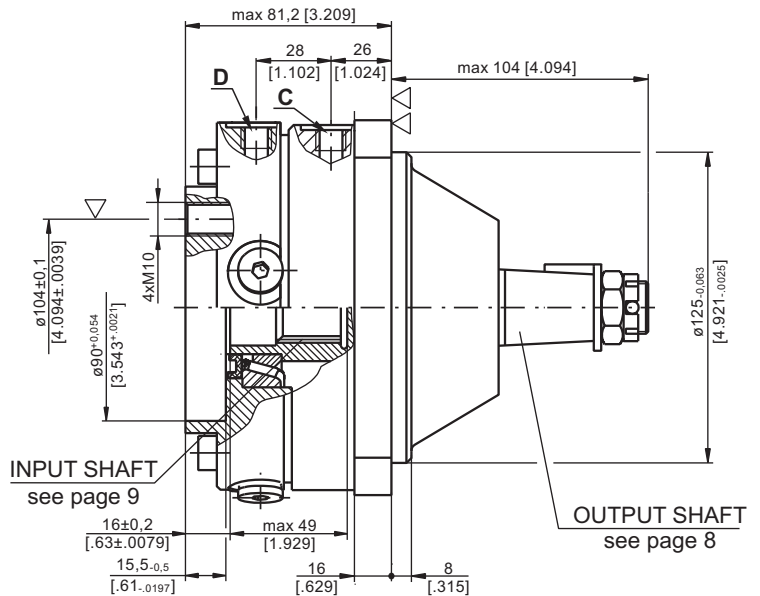
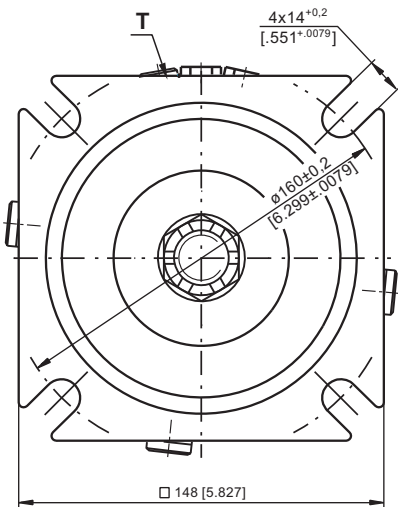

TYPE LBS/289(290)

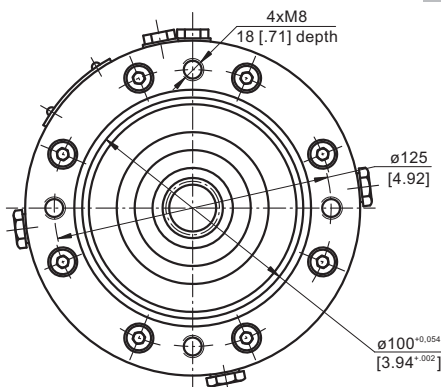

INPUT FACE For Versions 289 and 290

TYPE LBV/289(290)

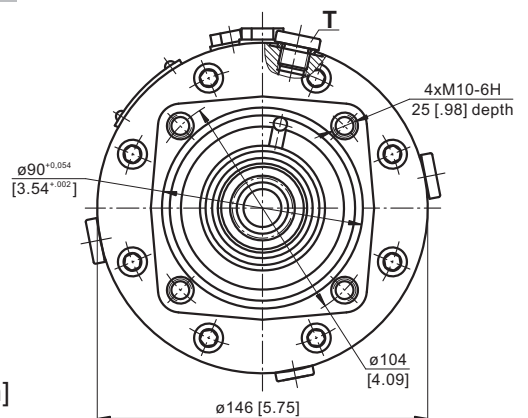

OUTPUT SHAFT EXTENSIONS

CB - $\phi 32$ straight, Parallel key A10x8x45 DIN 6885
Max. Torque 77 daNm [6815 lb-in]

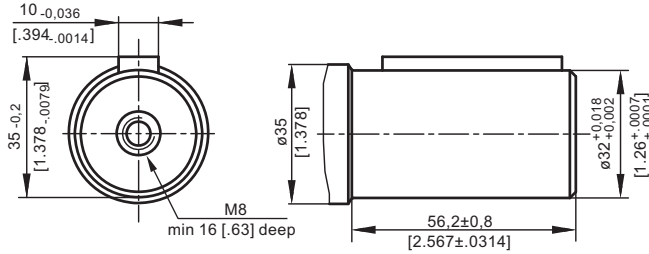

KB - tapered 1:10, Parallel key B6x6x20 DIN 6885
Max. Torque 95 daNm [8400 lb-in]

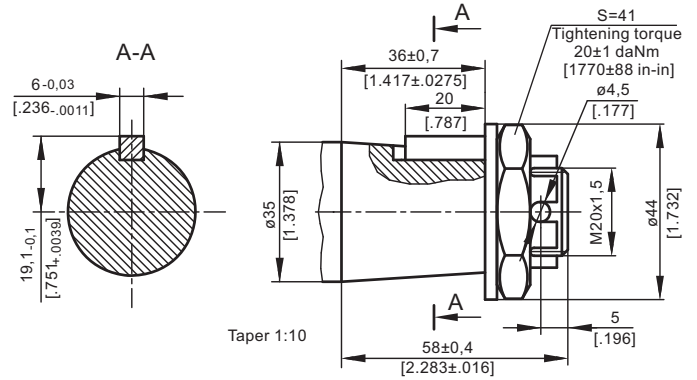

SPECIFICATION DATA

SH - $\phi 1\frac{1}{4}$ " splined 14T, DP12/24 ANS B92.1-1970
Max. Torque 95 daNm [8400 lb-in]

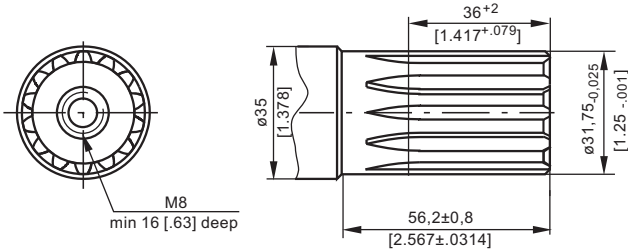

Description LBS/289(290) LBV/289(290)	21	32	43	63
*Min. Static Torque, daNm [lb-in]	20-22 [1770-1947]	31-34 [2743-3009]	41-45 [3628-3982]	61-64 [5399-5665]
Opening Pressure, bar [PSI]	min [174-188]	18-20 [260-290]	24-26 [348-377]	38-39 [550-565]
	max 300 [4350]			
Min. oil quantity for brake releasing cm ³ [in ³]	7 - 8 [0.427 - .488]			
Oil volume cm ³ [in ³]	50 - 120 [3.05 - 7.35]			
Max. Pressure in drain space bar [PSI]	5 [72]			
Weight kg [lb]	9 [19.8]			

*Static torque is obtained at working pressure - 0 bar [0 PSI].

LOAD CURVE

The curve applies to a B10 bearing life of 3000 hours at 200 RPM.

- 1: Pa < 350 daN [787 lbs]
- 2: Pa = 500 daN [1125 lbs]

LBS(V)/289

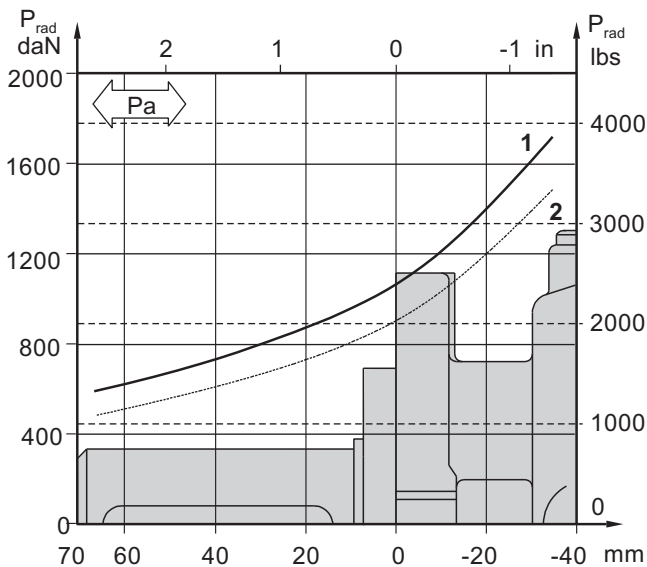

LBS(V)/290

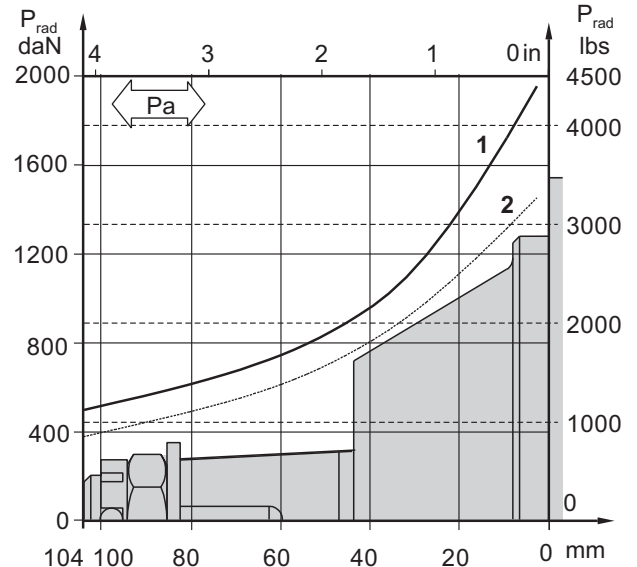

INTERNAL SPLINE DATA FOR THE ATTACHED COMPONENT

Standard ANS B92.1-1970, class 5

[m=2.1166]

Fillet Root Side Fit	LBS(V)/289 LBS(V)/290		LBS(V)/314 LBS(V)/315		
	mm	inch	mm	inch	
Number of Teeth	z	12	12	16	16
Diametral Pitch	DP	12/24	12/24	12/24	12/24
Pressure Angle		30°	30°	30°	30°
Pitch Dia.	D	25,4	1	33,8656	1.3333
Major Dia.	D _{ri}	28,0 ^{-0,1}	1.1 ± 1.098	38,4 ^{+0,4}	1.5118±1.5275
Minor Dia.	D _i	23,0 ^{+0,033}	.907 ± .905	32,15 ^{+0,06}	1.2657±1.2673
Space Width [Circular]	Lo	4,308±0,020	.1704 ± .1688	4,516±0,037	.1763±.1791
Fillet Radius	R	0,2	.008	0,5	.02
Max. Measurement between Pins	L	17,62 ^{+0,15}	.699 ± .694	26,9 ^{+0,10}	1.063±1.059
Pin Dia.	d	4,835±0,001	.19039±.19031	4,835±0,001	.19026±.19034
Corrected	x.m	+0,8	+0.031	+1,0	+0.039

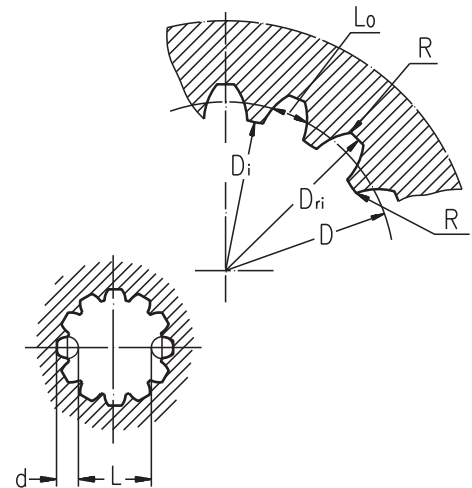

ORDER CODE - LB/288

	1	2	3	4	5
LB/288		-			

Pos.1 - Input Shaft Hole

C, CO, SH, CB, SB

Pos.2 - Static Torque code (See Specification data)

7, 14, 21, 32, 43, 63

Pos.3 - Output Shaft Extensions*

C - ø25 straight, Parallel key A8x7x32 DIN 6885

CO - ø1" straight, Parallel key ¼"x¼"x1¼" BS46

SH - ø25,32 splined BS 2059 (SAE 6B)

SA - ø24,5 splined B25x22 DIN 5482

CB - ø32 straight, Parallel key A10x8x45 DIN 6885

KB - ø35 tapered 1:10, Parallel key B6x6x20 DIN6885

Pos.4 - Option (Paint)**

omit - no Paint

P - Painted

PC - Corrosion Protected Paint

Pos.5 - Design Series

omit - Factory specified

ORDER CODE - LBS, LBV

	1	2	3	4	5	6
LB		/	-			

Pos.1 - Type

S - Disc Brake for short motor S- MSS

V - Disc Brake for very short motor V- MSV

Pos.2 - Design code

289 - for MSS and MSV Motors

290 - for MSS and MSV Motors (Wheel Mount)

Pos.3 - Static Torque code (See Specification data)

21, 32, 43, 63

Pos.4 - Output Shaft Extensions*

CB - ø32 straight, Parallel key A10x8x45 DIN 6885

KB - ø35 tapered 1:10, Parallel key B6x6x20 DIN6885

SH - ø1¼" splined 14T ANS B92.1-1970

Pos.5 - Option (Paint)**

omit - no Paint

P - Painted

PC - Corrosion Protected Paint

Pos.6 - Design Series

omit - Factory specified

NOTES:

* The permissible output torque for shafts must not be exceeded! For Max. Torque values see data on page 5 and 8.

** The color is by customer's request.

The Disc Brakes are mangano-phosphatized as standard.

ATTENTION:

- Hydraulic brake is delivered without oil (it is lubricated only).
- Hydraulic brake is filled through the drain port **D**. Space is filled with 50 ÷ 120 cm³ [3.05÷7.32 in³] mineral oil HLP (DIN 51524) or HM (ISO 6743/4). For LB/288 fill oil after hydraulic motor assembly.
- In all brakes, friction discs and separators should be lubricated.

**HYDRAULIC DISC BRAKES
FOR FLANGE ATTACHMENT TO MTS AND MTV HYDRAULIC MOTORS**

TYPE LBS/314

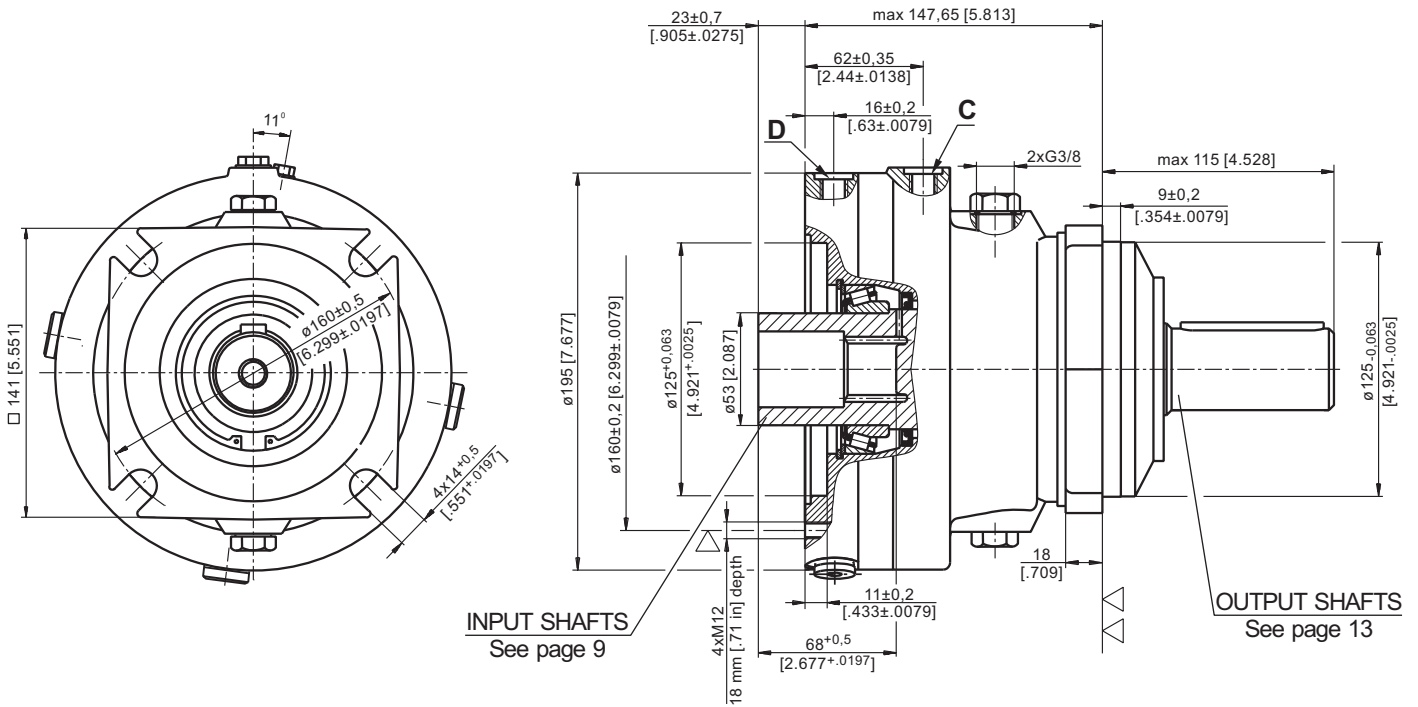

▽ - Place for attachment
(tightening torque for screw M12x30- 8.8 DIN 912,
7 daNm [620 lb-in])

C: Brake release Port - G $\frac{1}{4}$, 12 mm [.47 in] depth
D: Drainage tap - G $\frac{1}{4}$, 12 mm [.47 in] depth

▽▽ - Place for attachment

TYPE LBV/314

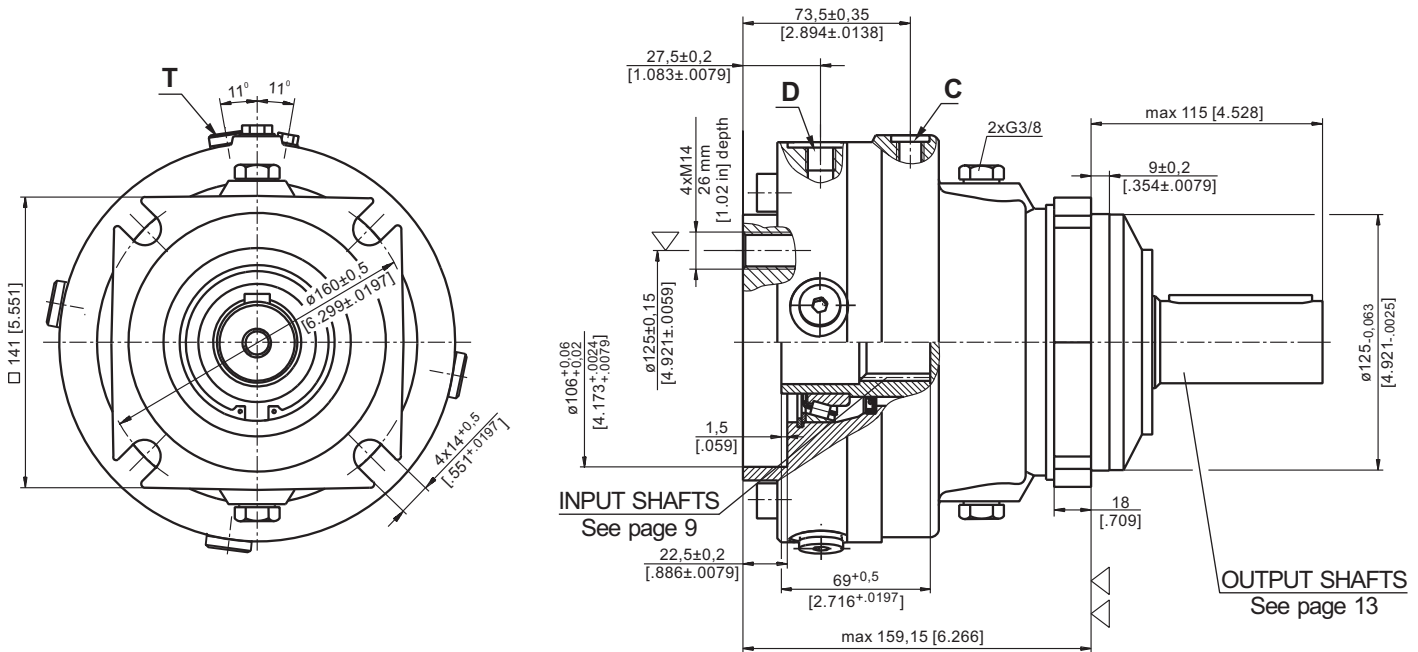

▽ - Place for attachment
(tightening torque for screw M14xL - 8.8 DIN 912,
11,5 daNm [1020 lb-in])

C: Brake release Port - G $\frac{1}{4}$, 9 mm [.35 in] depth
D: Drain plug for the Brake - G $\frac{1}{4}$, 9 mm [.35 in] depth
T: Drain plug for the Motor - G $\frac{1}{4}$, 9 mm [.35 in] depth

▽▽ - Place for attachment

**HYDRAULIC DISC BRAKES
FOR FLANGE ATTACHMENT TO MTS AND MTV HYDRAULIC MOTORS**

TYPE LBS/315

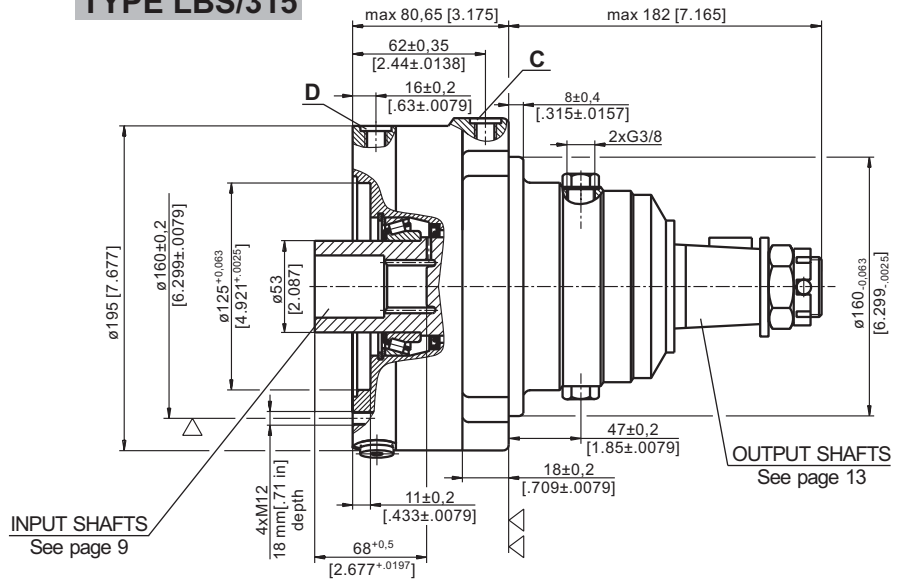
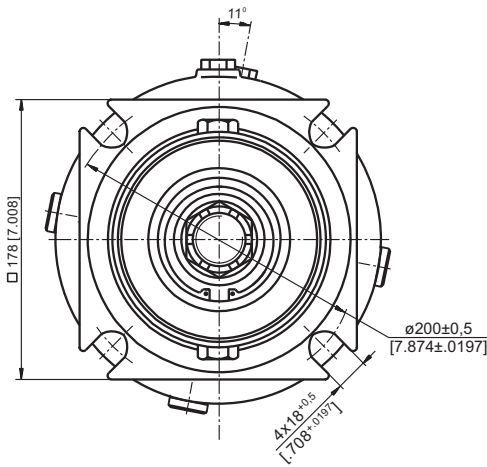

- ▽ - Place for attachment (tightening torque for screw M12x30- 8.8 DIN 912, 7 daNm [620 lb-in])
- ▽▽ - Place for attachment

- C:** Brake release Port - G $\frac{1}{4}$, 12 mm [.47 in] depth
- D:** Drainage tap - G $\frac{1}{4}$, 12 mm [.47 in] depth

TYPE LBV/315

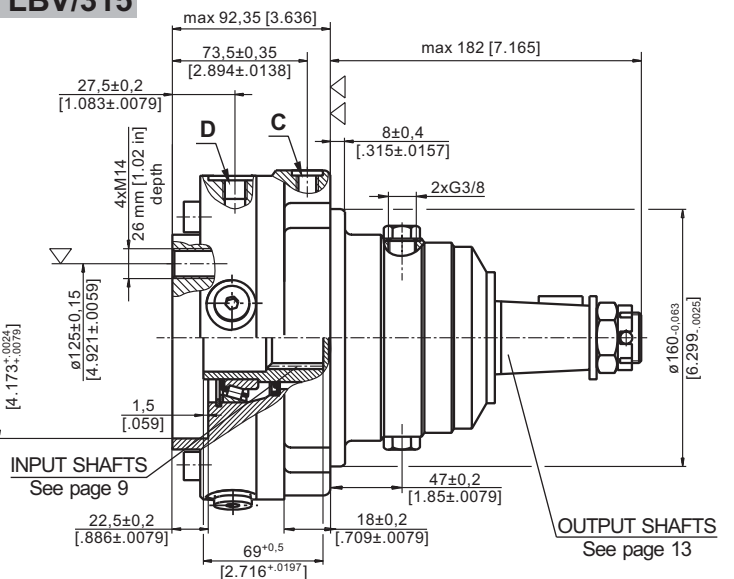
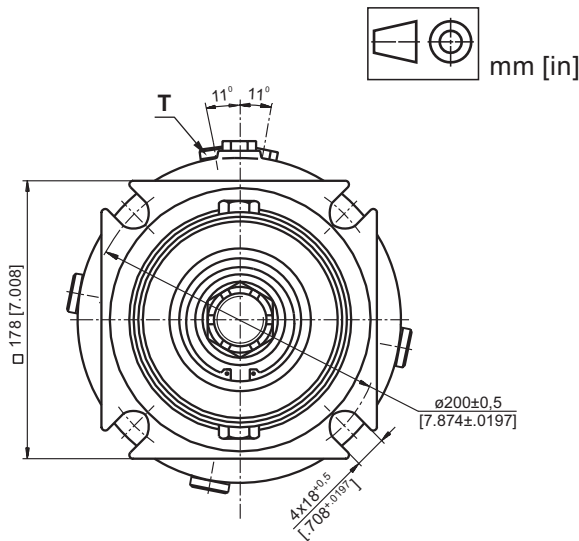

- ▽ - Place for attachment (tightening torque for screw M14xL - 8.8 DIN 912, 11,5 daNm [1020 lb-in])
- ▽▽ - Place for attachment

- C:** Brake release Port - G $\frac{1}{4}$, 9 mm [.35 in] depth
- D:** Drain plug for the Brake - G $\frac{1}{4}$, 9 mm [.35 in] depth
- T:** Drain plug for the Motor - G $\frac{1}{4}$, 9 mm [.35 in] depth

**INPUT FACE
For Versions 314 and 315**

TYPE LBS/314(315)

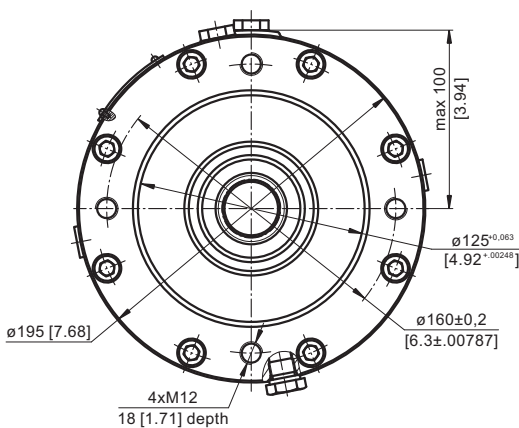

TYPE LBV/314(315)

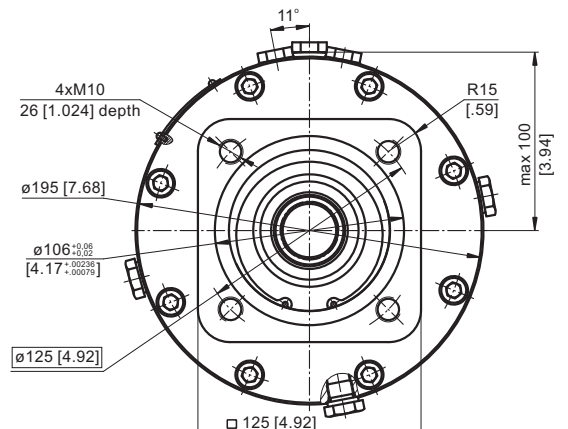

SPECIFICATION DATA

Description	LBS/314,315	21	29	43	65	85	110	130
*Min. Static Torque, daNm [lb-in]		18-23 [1593-2036]	28-33 [2478-2921]	42-46 [3717-4071]	61-70 [5399-6196]	83-92 [7346-8143]	108-118 [9559-10444]	126-136 [11152-12037]
Opening Pressure min** bar [PSI]		4-5 [58-72]	6-7 [87-101]	9-10 [130-145]	13-15 [188-217]	18-20 [261-290]	23-25 [333-362]	27-29 [391-420]
	max	300 [4350]						
Min. oil quantity for brake releasing cm ³ [in ³]		8-9 [.488-.549]						
Oil volume cm ³ [in ³]		250						
Max. Pressure in drain space bar [PSI]		5 [72]						
Weight for .../314 kg [lb]		24 [52.9]						
	.../315	25 [55.1]						

*Static torque is obtained at working pressure - 0 bar.

**The indicated value is a difference between the inlet pressure for driving of the brake and the drain pressure.

Brakes must always have a drain line

LOAD CURVE

LBS(V) ... /314

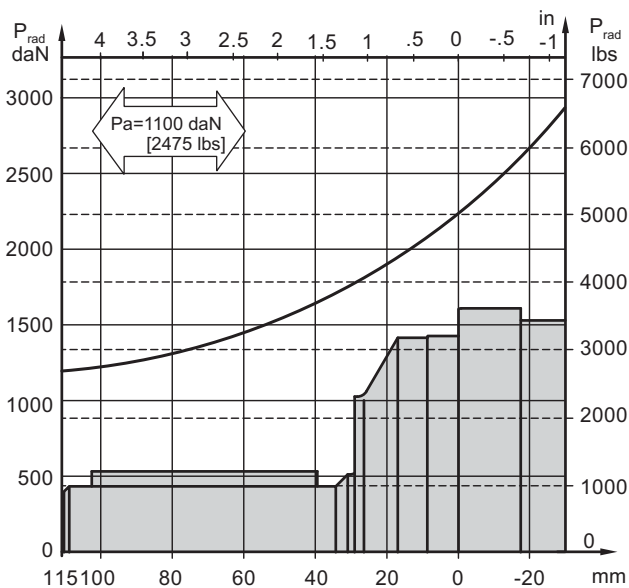

LBS(V) ... /315

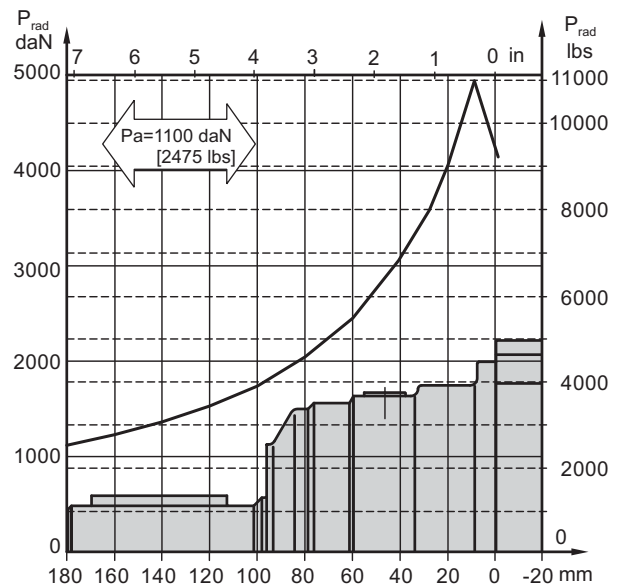

OUTPUT SHAFT EXTENSIONS

C - \varnothing 40 straight, Parallel key A12x8x70 DIN 6885
Max. Torque 132,8 daNm [11755 In-in]

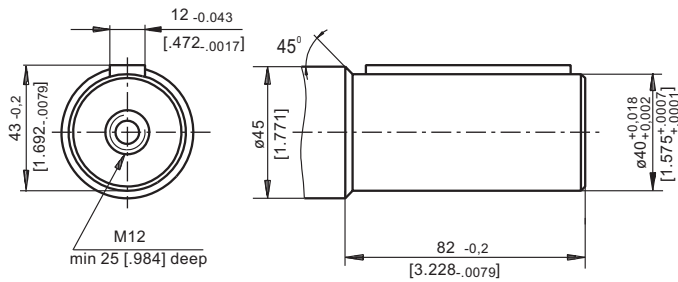

K -tapered 1:10, Parallel key B12x8x28 DIN 6885
Max. Torque 210,7 daNm [18650 lb-in]

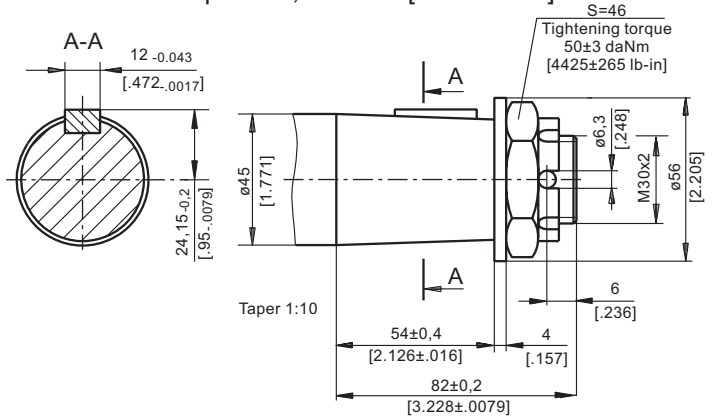

CO - \varnothing 1 1/2" straight, Parallel key 3/8" x 3/8" x 2 1/4" BS46
Max. Torque 132,8 daNm [11755 In-in]

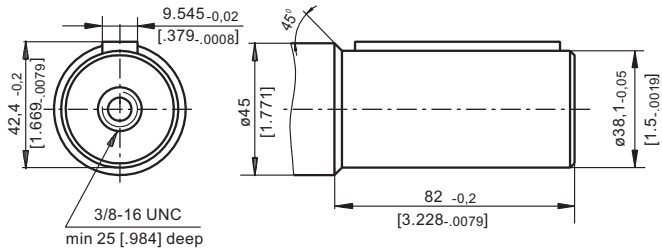

SH - \varnothing 1 1/2" splined 17T, DP 12/24 ANSI B92.1-1976
Max. Torque 132,8 daNm [11755 In-in]

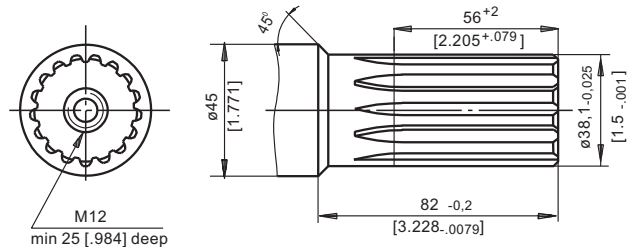

ORDER CODE

1	2	3	4	5	6
LB	/	-			

Pos.1 - Type

- S** - Disc Brake for short motor **S** - MTS
- V** - Disc Brake for very short motor **V** - MTV

Pos.2 - Design code

- 314** - for MTS and MTV Motors
- 315** - for MTS and MTV Motors (Wheel Mount)

Pos.3 - Static Torque code (See Specification data)

21, 29, 43, 65, 85, 110, 130

Pos.4 - Output Shaft Extensions*

- C** - \varnothing 40 straight, Parallel key A12x8x70 DIN 6885
- CO** - \varnothing 1 1/2" straight, Parallel key 3/8" x 3/8" x 2 1/4" BS46
- SH** - \varnothing 1 1/2" splined 17T, ANSI B92.1-1976
- K** - \varnothing 45 tapered 1:10, Parallel key B12x8x28 DIN6885

Pos.5 - Option (Paint)**

- omit - no Paint
- P** - Painted
- PC** - Corrosion Protected Paint

Pos.6 - Design Series

- omit - Factory specified

NOTES:

- * The permissible output torque for shafts must not be exceeded!
- ** The color is by customer's request.

The Disc Brakes are manganophosphated as standard.

ATTENTION:

- Hydraulic brake is delivered without oil (it is lubricated only).
- Hydraulic brake is filled through the drain port **D**. Space is filled with 50 ÷ 120 cm³ [3.05 ÷ 7.32 in³] mineral oil HLP (DIN 51524) or HM (ISO 6743/4). For LB/288 fill oil after hydraulic motor assembly.
- In all brakes, friction discs and separators should be lubricated.

**HYDRAULIC DISC BRAKES
FOR FLANGE ATTACHMENT TO MVS HYDRAULIC MOTORS**

Type LBS/313

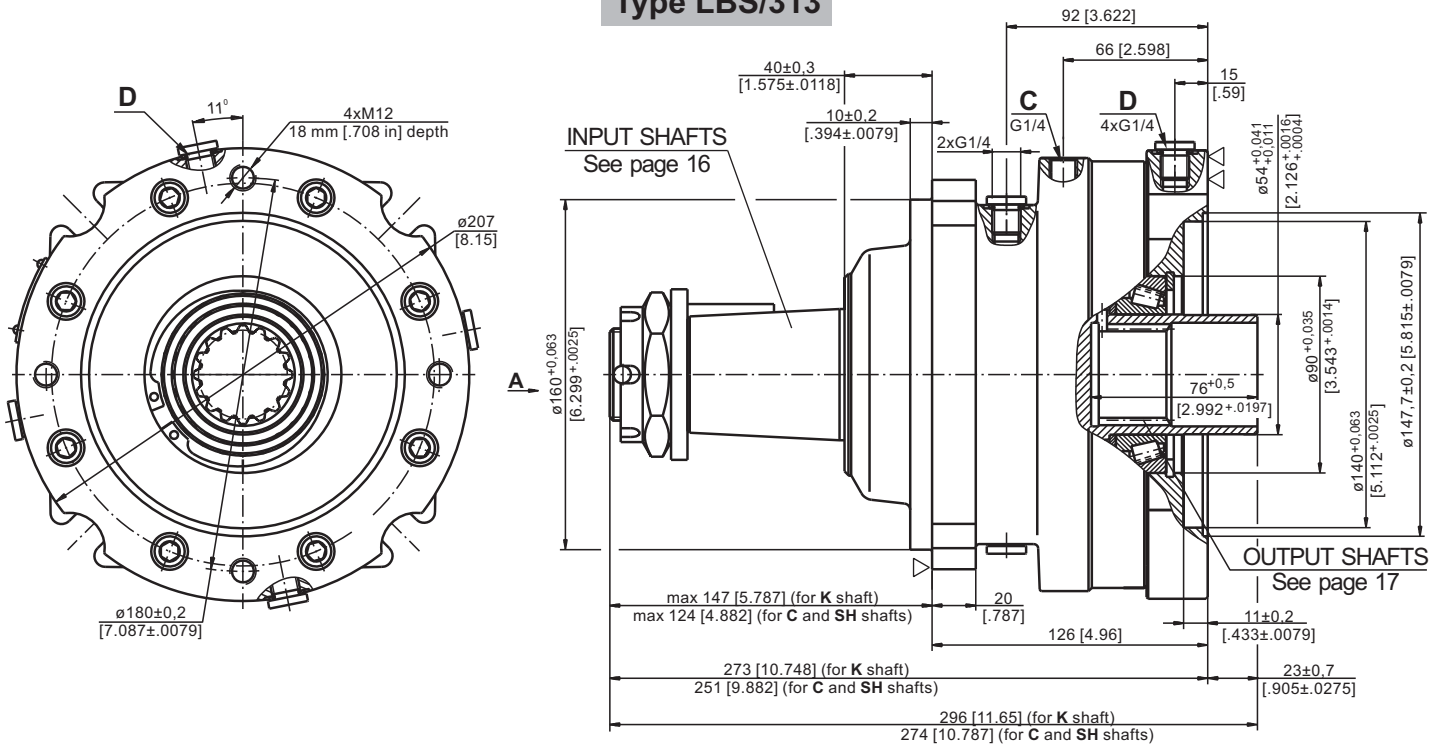

C: Brake release Port - G $\frac{1}{4}$, 12 mm [.47 in] depth
D: Drainage tap - G $\frac{1}{4}$, 12 mm [.47 in] depth

▽ - Place for attachment
 ▽ - Place for attachment
 (tightening torque for screw M12x35 - 8.8 DIN 912,
 7 daNm [620 lb-in])

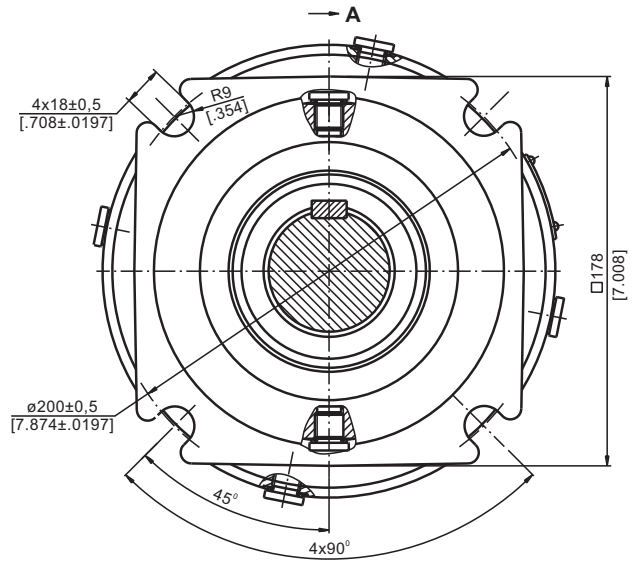

PERMISSIBLE SHAFT LOADS

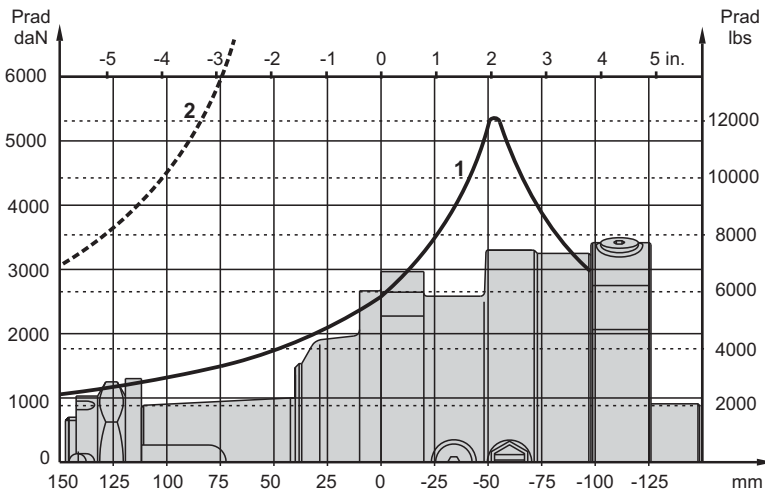

1 - Bearing curve: The curve applies to a B10 bearing life of 3000 hours at 200 RPM.
2 - Shaft curve: The curve represents Max. permissible radial shaft load with safety factor 3:1.

HYDRAULIC DISC BRAKES FOR FLANGE ATTACHMENT TO MVS HYDRAULIC MOTORS

Type LBS/316

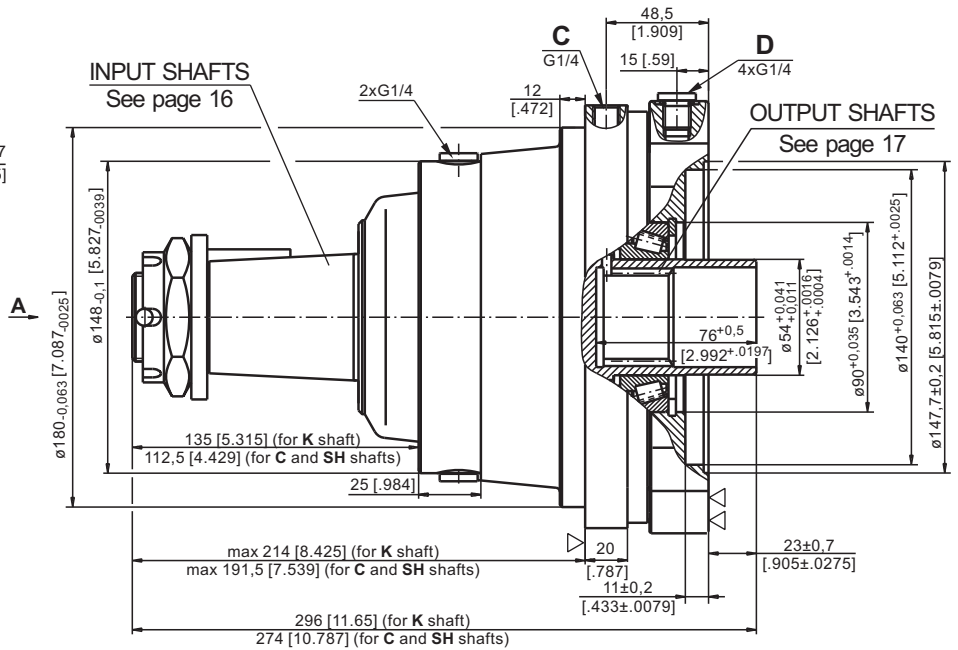
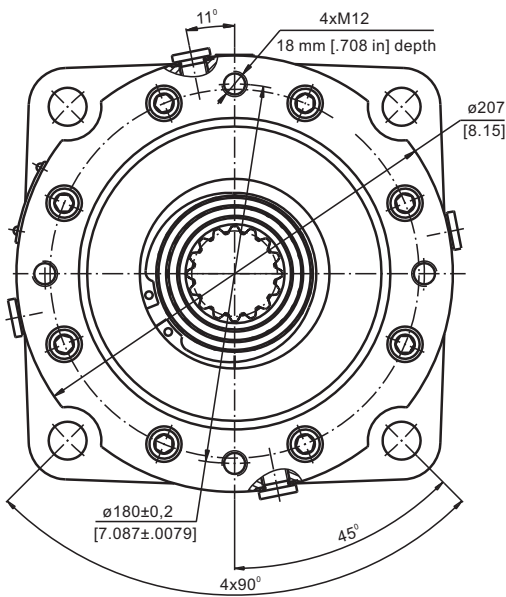

C: Brake release Port - G $\frac{1}{4}$, 12 mm [0.47 in] depth

D: Drainage tap - G $\frac{1}{4}$, 12 mm [0.47 in] depth

▽- Place for attachment

▽▽- Place for attachment (tightening torque for screw M12x35 - 8.8 DIN 912, 7 daNm [620 lb-in])

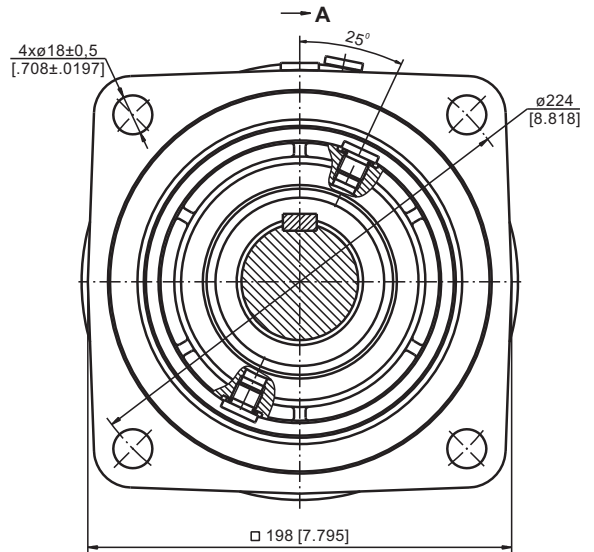

PERMISSIBLE SHAFT LOADS

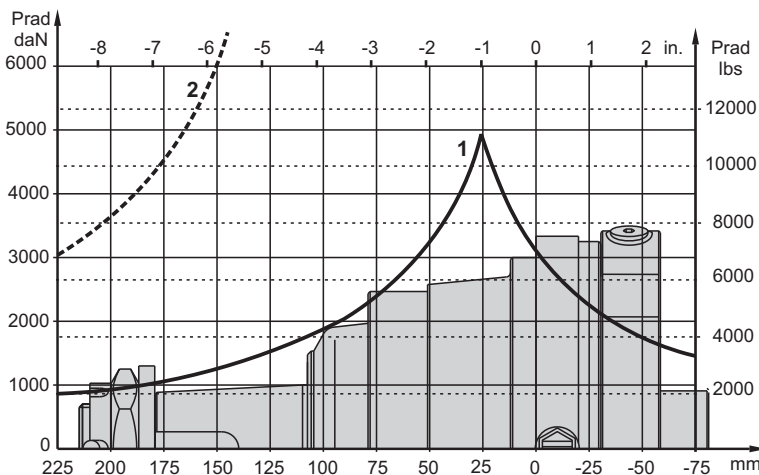

- 1 - Bearing curve: The curve applies to a B10 bearing life of 3000 hours at 200 RPM.
- 2 - Shaft curve: The curve represents Max. permissible radial shaft load with safety factor 3:1.

SPECIFICATION DATA

Description LBS/313,316	21	29	43	65	85	110	130
*Min. Static Torque, daNm [lb-in]	18-23 [1593-2036]	28-33 [2478-2921]	42-47 [3717-4160]	61-71 [5399-6285]	83-94 [7346-8320]	108-118 [9559-10444]	127-137 [11240-12125]
Opening Pressure min** bar [PSI]	4-5 [58-72]	6-7 [87-101]	9-10 [130-145]	13-15 [188-217]	18-20 [261-290]	23-25 [333-362]	27-29 [391-420]
	max 300 [4350]						
Min. oil quantity for brake releasing cm ³ [in ³]	8 ÷ 9 [.488 ÷ .549]						
Oil volume cm ³ [in ³]	250 [15.25]						
Max. Pressure in drain space bar [PSI]	5 [72]						

*Static torque is obtained at working pressure - 0 bar.

**The indicated value is a difference between the inlet pressure for driving of the brake and the drain pressure.

Brakes must always have a drain line

SHAFT EXTENSIONS

C - ø50 straight, Parallel key A14x9x70 DIN 6885

SH - ø21/8" splined, 16 DP 8/16 ANS B92.1-1976

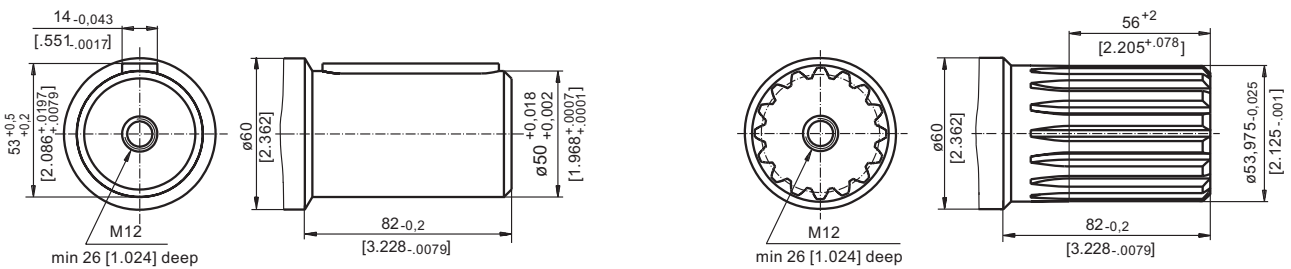

K -tapered 1:10, Parallel key B16x10x32 DIN 6885

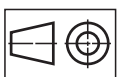
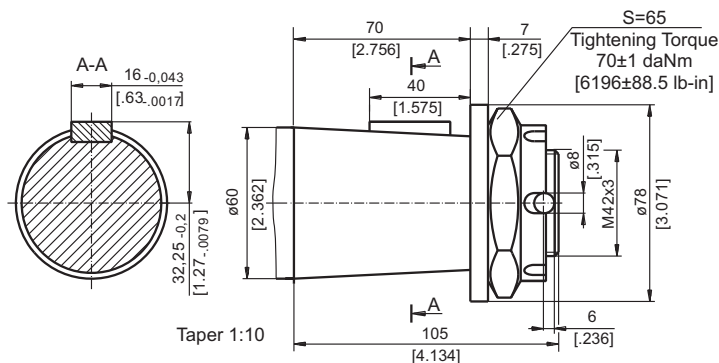

mm [in]

INTERNAL SPLINE DATA FOR THE ATTACHED COMPONENT

Standard ANS B92.1-1970, class 5
[$m=2.54$; corrected $x.m=+1,0$]

Fillet Root Side Fit		mm	inch
Number of Teeth	z	16	16
Diametral Pitch	DP	10/20	10/20
Pressure Angle		30°	30°
Pitch Dia.	D	40,640	1.6
Major Dia.	D _{ri}	45,2 ^{+0,4}	1.796÷1.780
Minor Dia.	D _i	38,5 ^{+0,039}	1.5175÷1.516
Space Width [Circular]	L _o	5,18±0,037	.2055±.2025
Fillet Radius	R	0,4	.015
Max. Measurement between Pins	L	32,47 ^{+0,15}	1.284±1.278
Pin Dia.	d	5,6±0,001	.22051±.22043

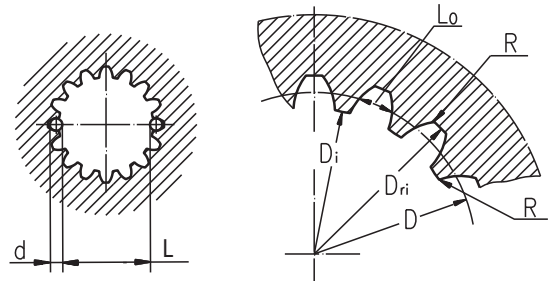

Hardening Specification:
HV=750±50 on the surface.
HV=560 at 0,7±0,2 mm [.035±.019in] case depth
Material: 20 MoCr4 EN 10084 or better.

ORDER CODE

	1	2	3	4	5
LBS/		-			

Pos.1 - Designe code

313 - for MVS Motors

316 - for MVS Motors (Wheel mount)

Pos.2 - Static Torque code (See Specification data)

21, 29, 43, 65, 85, 110, 130

Pos.3 - Output Shaft Extensions*

C - ø50 straight, Parallel key A14x9x70 DIN6885

SH - ø2 1/8" splined, ANSI B92.1-1976

K - ø60 tapered 1:10, Parallel key B16x10x32 DIN6885

Pos.4 - Option (Paint)**

omit - no Paint

P - Painted

PC - Corrosion Protected Paint

Pos.5 - Design Series

omit - Factory specified

NOTES:

* The permissible output torque for shafts must be not exceeded!

** The color is by customer's request.

The Disc Brakes are mangano-phosphatized as standard.

ATTENTION:

1. Hydraulic brake is delivered without oil (it is lubricated only).

2. In all brakes, friction discs and separators should be lubricated. Space is filled with 150 ÷ 300 cm³ [9.15 ÷ 18.3 in³] mineral oil HLP (DIN 51524) or HM (ISO 6743/4).

HYDRAULIC DISC BRAKES B...R- Wet

B...R brake is designed to be mounted to the wheels of low-speed agricultural and construction vehicles.

The advantage of these brakes is that despite the smallest possible dimensions they preserve long-term life of the bearings at high radial shaft load.

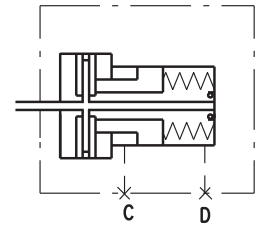

SPECIFICATION DATA

Type	B35R	B55R
Static Torque of Brake, daNm [lb-in]*	35 [3100]	55 [4870]
Initial Release Pressure, bar [PSI]	16 [232]	16 [232]
Full Release Pressure, bar [PSI]	19 [275]	19 [275]
Max. Operating Pressure, bar [PSI]	240 [3480]	240 [3480]
Max. Speed, RPM	90	90
Cont. Radial Shaft Load daN [lbs]**	500 [1125]	500 [1125]
Max. Radial Shaft Load daN [lbs]***	700 [1575]	900 [2030]

* At 0 bar [0 PSI] back pressure

** At radial shaft load of 500 daN [1125 lbs], applied at center-line of the key and speed of rotation 90 RPM, the bearing life is 1000 hours.

*** The permissible values of radial shaft load may occur for max. 10% of every minute

DIMENSIONS AND MOUNTING DATA

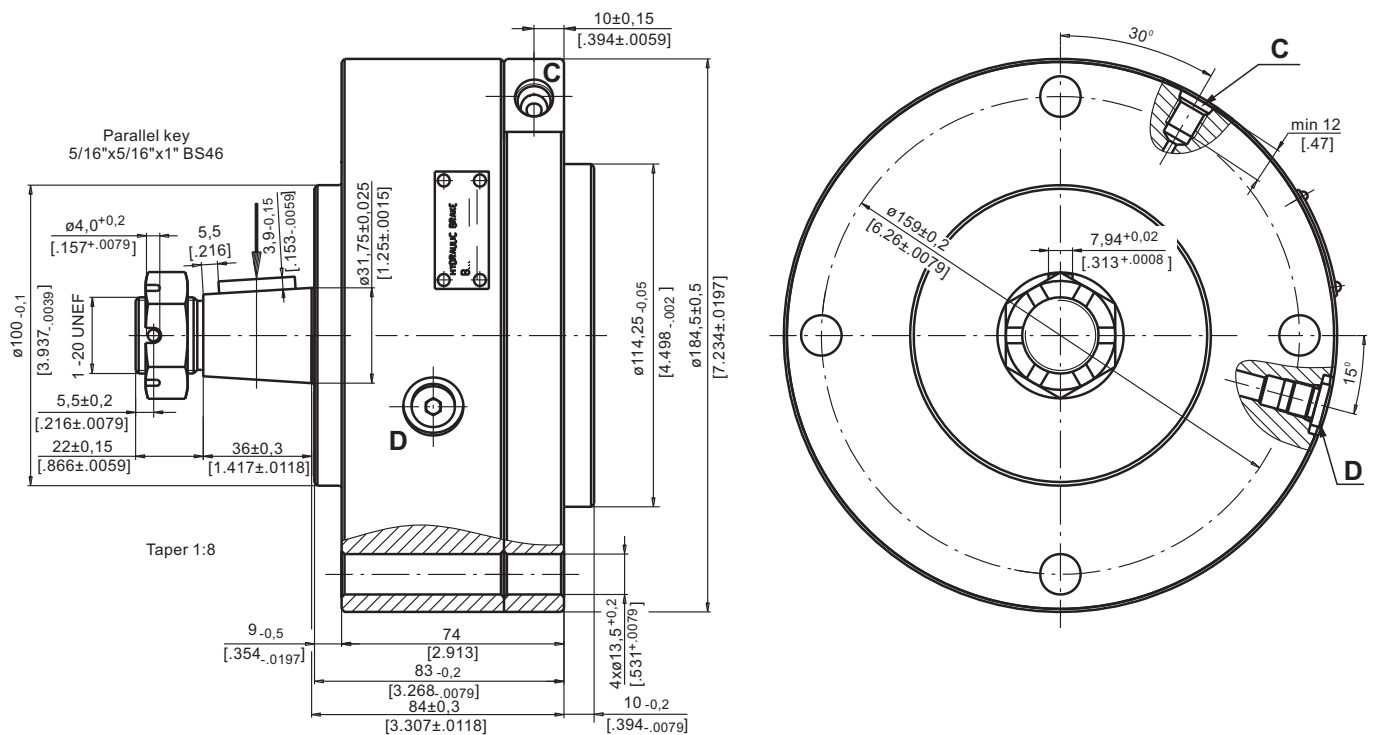

- C : Brake Release Port -7/16-20 UNF
SAE J1926-1/ISO 11926-1
- D : Drainage Tap - 7/16-20 UNF



HYDRAULIC DISC BRAKES B...T- Wet

B..T brake is designed to be mounted to the wheels of low-speed agricultural and construction vehicles.

The advantage of these brakes is that despite the smallest possible dimensions they preserve long-term life of the bearings at high radial shaft load.

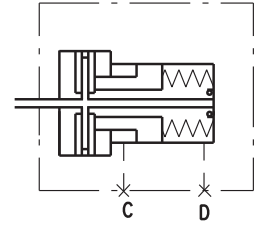

SPECIFICATION DATA

Type	B50T	B55T	B60T	B65T	B85T
Static Torque of Brake, daNm [lb-in]*	50 [4425]	55 [4870]	60 [5310]	65 [5750]	85 [7525]
Initial Release Pressure, bar [PSI]	16 [232]	16 [232]	16 [232]	17 [246]	18 [260]
Full Release Pressure, bar [PSI]	19 [275]	19 [275]	19 [275]	20 [290]	22 [320]
Max. Operating Pressure, bar [PSI]	240 [3480]	240 [3480]	240 [3480]	240 [3480]	240 [3480]
Max. Speed, RPM	60	60	60	60	60
Cont. Radial Shaft Load daN [lbs]**	1000 [2250]	1000 [2250]	1000 [2250]	1000 [2250]	1500 [3370]
Max. Radial Shaft Load daN [lbs]***	2150 [4830]	2150 [4830]	2150 [4830]	2150 [4830]	2250 [5060]

* At 0 bar [0 PSI] back pressure

** At radial shaft load of 1000 daN [2250 lbs], applied at center-line of the key and speed of rotation 60 RPM, the bearing life is 1000 hours.

*** The permissible values of radial shaft load may occur for max. 10% of every minute

DIMENSIONS AND MOUNTING DATA

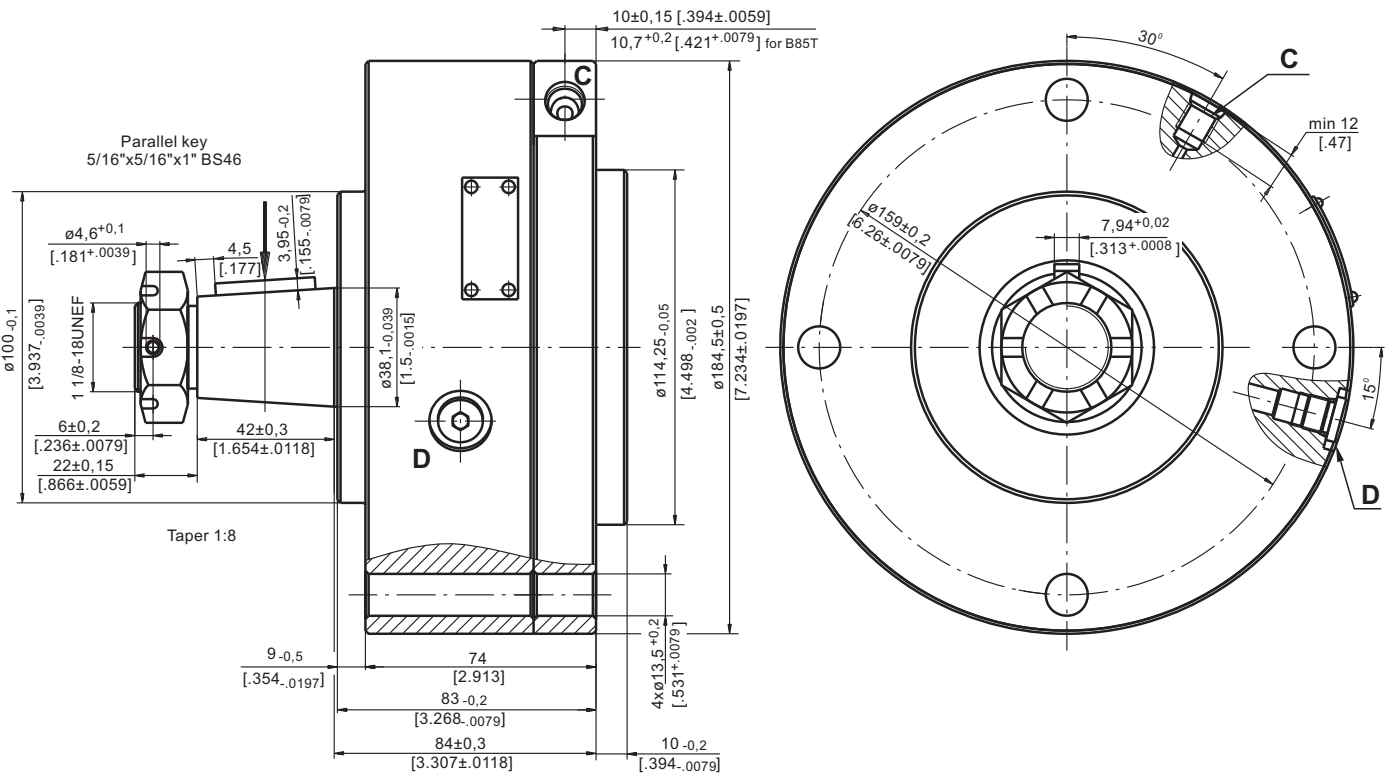

C : Brake Release Port - 7/16-20 UNF
SAE J1926-1/ISO 11926-1

D : Drainage Tap - 7/16-20 UNF



HYDRAULIC DISC BRAKES B130K...- Wet

This brake is designed to be mounted to the wheels of low-speed agricultural and construction vehicles.

The advantage of these brakes is that despite the smallest possible dimensions they preserve long-term life of the bearings at high radial shaft load.

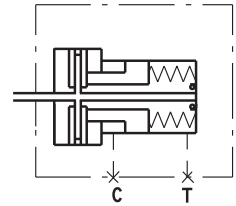

SPECIFICATION DATA

Type	B130K
Static Torque of Brake, daNm [lb-in]*	143 [12565]
Min. Brake Release Pressure, bar [PSI]	31-33 [119-478]
Max. Opening Pressure, bar [PSI]	280 [4060]
Max. Permissible Pressure in Drain Line, bar [PSI]	5 [72]
Weight, kg [lb]	18,5 [40.8]

* At 0 bar [0 PSI] back pressure

DIMENSIONS AND MOUNTING DATA

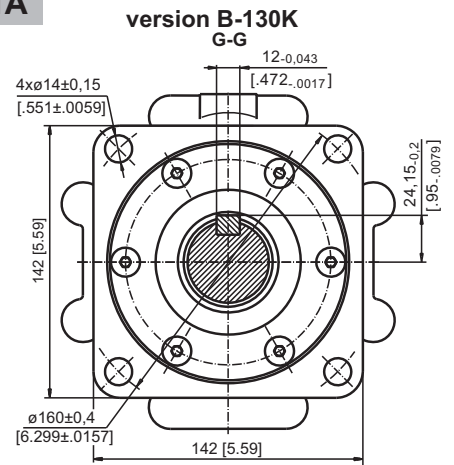
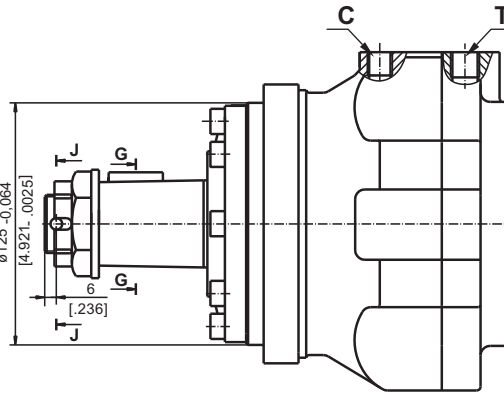
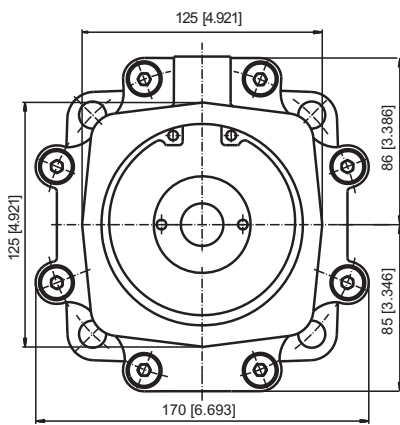

version B-130K

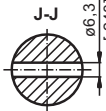

version B-130K-P

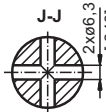

K -tapered 1:10,
Parallel key B12x8x28 DIN 6885
Max. Torque 210 daNm [18587 lb-in]

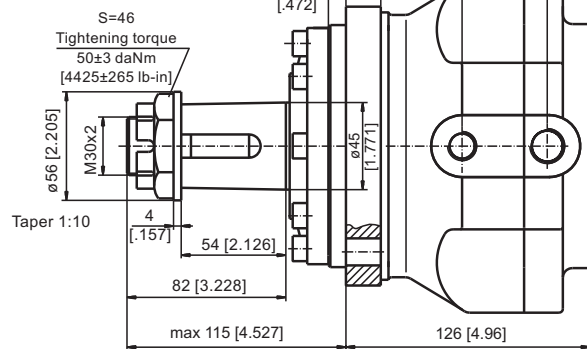

version B-130K-P

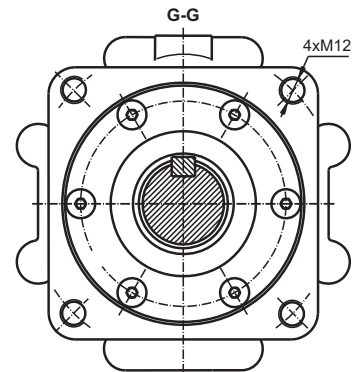

- C - Brake release port, G1/4,
12 mm [0.472 in] depth
- D - Drainage tap, G3/8,
13 mm [0.512 in] depth

PERMISSIBLE SHAFT LOADS

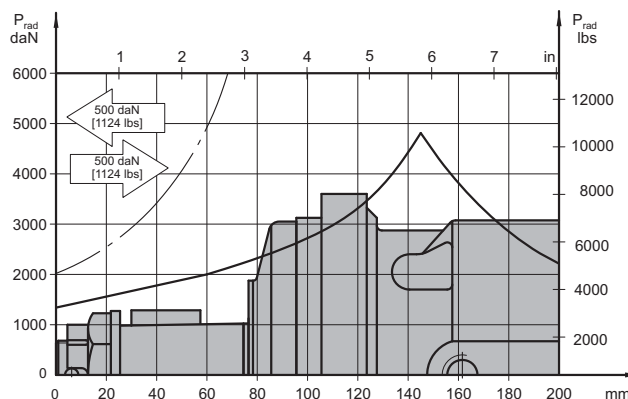

The curve applies to a B10 bearing life of 3000 hours at 200 RPM.

HYDRAULIC MOTOR-BRAKE B/MR



APPLICATION

- » Conveyors
- » Feeding mechanism of robots and manipulators
- » Metal working machines
- » Textile machines
- » Agricultural machines
- » Food industries
- » Mining machinery etc.

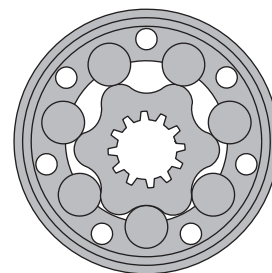

CONTENTS

Specification data22+23
 Dimensions and mounting 24+25
 Shaft extensions 25
 Permissible shaft loads 26
 Order code 26

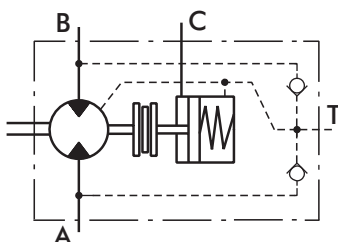

OPTIONS

- » Model - Spool valve, roll-gerotor
- » Fully integrated friction disk brake
- » Side port
- » Shaft - straight
- » BSPP ports

GENERAL

Max. Displacement, cm ³ /rev [in ³ /rev]	397 [24.4]
Max. Speed, [RPM]	600
Max. Torque, daNm [lb-in]	cont.: 61 [5400] int.: 57 [5045]
Max. Output, kW [HP]	14,5 [19.5]
Max. Pressure Drop, bar [PSI]	cont.: 175 [2540] int.: 200 [2900]
Max. Oil Flow, lpm [GPM]	75 [19.8]
Min. Speed, [RPM]	10
Permissible Shaft Loads, daN [lb-in]	P _a =200 [450]
Pressure fluid	Mineral based- HLP(DIN 51524) or HM(ISO 6743/4)
Temperature range, °C [°F]	-40÷140 [-40÷284]
Optimal Viscosity range, mm ² /s [SUS]	20÷75 [98÷347]
Filtration	ISO code 20/16 (Min. recommended fluid filtration of 25 microns)

Oil flow in drain line

Pressure drop bar [PSI]	Viscosity mm ² /s [SUS]	Oil flow in drain line lpm [GPM]
100 [1450]	20 [98]	2,5 [.660]
	35 [164]	1,8 [.476]
140 [2030]	20 [98]	3,5 [.925]
	35 [164]	2,8 [.740]

Pressure Losses

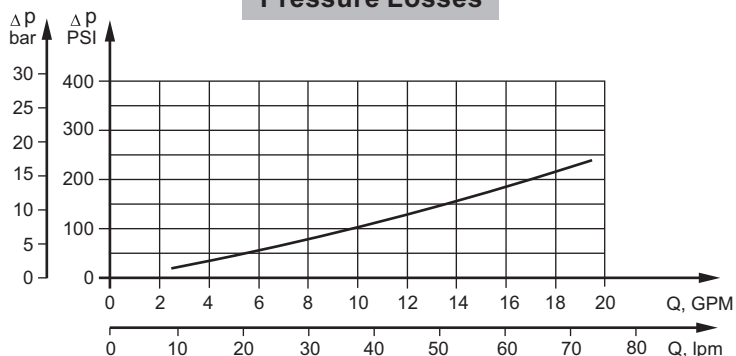

SPECIFICATION DATA

Type		B/MR 80	B/MR 100	B/MR 125	B/MR 160	B/MR 160 CB	B/MR 200	B/MR 200 CB
Displacement, cm ³ /rev [in ³ /rev]		80,3 [4.90]	99,8 [6.09]	125,7 [7.67]	159,6 [9.74]		199,8 [12.19]	
Max. Speed, [RPM]	Cont.	500	500	475	375		300	
	Int.*	600	600	600	470		375	
Max. Torque daNm [lb-in]	Cont.	19,5[1725]	24[2125]	30[2655]	30[2655]	39[3450]	30[2655]	45[3980]
	Int.*	22[1947]	28[2480]	34[3010]	39[3450]	43[3805]	39[3450]	50[4425]
	Peak**	27[2390]	32[2832]	37[3275]	46[4070]	46[4070]	56[4960]	56[4955]
Max. Output kW [HP]	Cont.	8,4 [11.2]	10,8 [14.5]	12,5 [16.8]	10 [13.4]	11,5 [15.4]	7,8 [10.5]	11 [14.75]
	Int.*	9,6 [12.9]	12 [16.1]	14,5 [19.5]	12,5 [16.8]	14 [18.8]	12,4 [16.6]	13 [17.4]
Max. Pressure Drop, bar [PSI]	Cont.	175[2540]	175[2540]	175[2540]	135[1960]	175[2540]	105[1523]	175[2540]
	Int.*	200[2900]	200[2900]	200[2900]	175[2540]	200[2900]	145[2103]	200[2900]
	Peak**	225[3263]	225[3263]	225[3263]	225[3263]	225[3263]	225[3263]	225[3263]
Max. Oil Flow l/min [GPM]	Cont.	40 [10.5]	50 [13.2]	60 [15.9]	60 [15.9]		60 [15.9]	
	Int.*	48 [12.7]	60 [15.9]	75 [19.8]	75 [19.8]		75 [19.8]	
Max. Inlet Pressure bar [PSI]	Cont.	175 [2540]						
	Int.*	200 [2900]						
	Peak**	225 [3260]						
Max. Starting Pressure bar [PSI]		10 [145]	10 [145]	9 [130]	7 [102]		5 [73]	
Min. Starting Torque, daNm [lb-in]	At max.press.drop Cont	15 [1330]	20 [1770]	25 [2215]	24 [2124]	32 [2832]	26 [2301]	41 [3628]
	At max.press.drop Int.*	17 [1505]	23 [2035]	28 [2480]	32 [2832]	37 [3275]	33 [2920]	46 [4071]
Min. Speed***, [RPM]		10	10	10	10	10	10	10
Static Torque of Brake, daNm [lb-in]		55 [4868]						
Min. Brake Release Pressure****, bar [PSI]		13 [190]						
Max. Opening Pressure, bar [PSI]		200 [2900]						
Weight, kg [lb]		11,0 [24.3]	11,2 [24.7]	11,4 [25.2]	11,6 [25.6]	11,7 [25.8]	12,2 [26.9]	12,3 [27.12]

* Intermittent operation: the permissible values may occur for max. 10% of every minute.

** Peak load: the permissible values may occur for max. 1% of every minute.

*** For speeds lower than given, consult factory or your regional manager.

**** Motor-brakes must always have a drain line. The brake release pressure is the difference between the pressure in the brake release line and the pressure in the drain line.

- Intermittent speed and intermittent pressure must not occur simultaneously.
- Recommended filtration is per ISO cleanliness code 20/16. A nominal filtration of 25 micron or better.
- Recommend using a premium quality, anti-wear type mineral based hydraulic oil HLP(DIN51524) or HM (ISO 6743/4). If using synthetic fluids consult the factory for alternative seal materials.
- Recommended minimum oil viscosity 13 mm²/s [70 SUS] at 50°C [122°F].
- Recommended maximum system operating temperature is 82°C [180°F].
- To assure optimum motor life fill with fluid prior to loading and run at moderate load and speed for 10-15 minutes.

SPECIFICATION DATA (continued)

Type		B/MR 250	B/MR 250 CB	B/MR 315	B/MR 315 CB	B/MR 400	B/MR 400 CB
Displacement, cm ³ /rev [in ³ /rev]		250,1 [15.26]		315,7 [19.26]		397 [24.4]	
Max. Speed, [RPM]	Cont.	240		190		150	
	Int.*	300		240		190	
Max. Torque daNm [lb-in]	Cont.	30 [2655]	54 [4780]	30 [2655]	55 [4868]	30 [2655]	55 [4868]
	Int.*	39 [3450]	57 [5045]	42 [3717]	57 [5045]	43 [3805]	57 [5045]
	Peak**	60 [5310]	71 [6285]	61 [5400]	71 [6285]	60 [5310]	70 [6195]
Max. Output kW [HP]	Cont.	6,2 [8.3]	10 [13.4]	4,5 [6.1]	9 [12.1]	2,2 [2.9]	7 [9.4]
	Int.*	9,5 [12.7]	11 [14.7]	7,5 [10.1]	10 [13.4]	5,6 [7.5]	8,7 [11.7]
Max. Pressure Drop, bar [PSI]	Cont.	85 [1233]	175 [2540]	65 [942]	135 [1958]	45 [652]	105 [1523]
	Int.*	115 [1668]	185 [2683]	90 [1305]	145 [2103]	75 [1087]	115 [1668]
	Peak**	200 [2900]	225 [3263]	150 [2175]	180 [2610]	120 [1740]	140 [2030]
Max. Oil Flow l/min [GPM]	Cont.	60 [15.9]					
	Int.*	75 [19.8]					
Max. Inlet Pressure bar [PSI]	Cont.	175 [2540]					
	Int.*	200 [2900]					
	Peak**	225 [3260]					
Max. Starting Pressure bar [PSI]		5 [73]		5 [73]		5 [73]	
Min. Starting Torque, daNm [lb-in]	At max.press.drop Cont	24 [2125]	50 [4425]	26 [2300]	50 [4425]	24 [2125]	44 [3895]
	At max.press.drop Int.*	31 [2745]	51,5 [4560]	35 [3100]	51,8 [4585]	38 [3364]	50 [4425]
Min. Speed***, [RPM]		10	10	10	10	10	10
Static Torque of Brake, daNm [lb-in]		55 [4868]					
Min. Brake Release Pressure****, bar [PSI]		13 [190]					
Max.Opening Pressure, bar [PSI]		200 [2900]					
Weight, kg [lb]		12,6[27.8]	12,7 [28]	13,3[29.3]	13,4[29.5]	14 [30.9]	14,1[31.1]

* Intermittent operation: the permissible values may occur for max. 10% of every minute.

** Peak load: the permissible values may occur for max. 1% of every minute.

*** For speeds lower than given, consult factory or your regional manager.

**** Motor-brakes must always have a drain line. The brake release pressure is the difference between the pressure in the brake release line and the pressure in the drain line.

- Intermittent speed and intermittent pressure must not occur simultaneously.
- Recommended filtration is per ISO cleanliness code 20/16. A nominal filtration of 25 micron or better.
- Recommend using a premium quality, anti-wear type mineral based hydraulic oil HLP(DIN51524) or HM (ISO 6743/4). If using synthetic fluids consult the factory for alternative seal materials.
- Recommended minimum oil viscosity 13 mm²/s [70 SUS] at 50°C [122°F].
- Recommended maximum system operating temperature is 82°C [180°F].
- To assure optimum motor life fill with fluid prior to loading and run at moderate load and speed for 10-15 minutes.

DIMENSIONS AND MOUNTING DATA

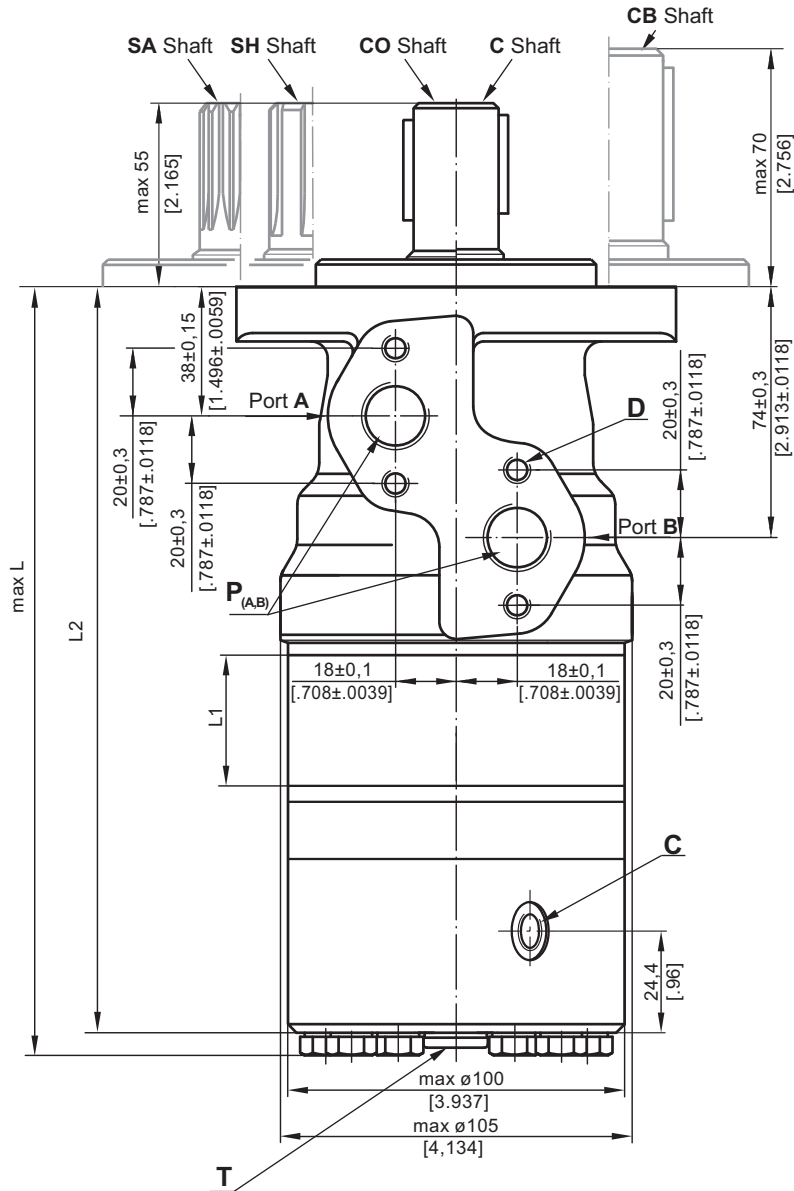

Shaft Dim.
See Page 25

Flange Dim.
See Page 25

- D** : 4xM8 - 13 mm [.51 in] depth
- C** : G1/4 - 12 [.47 in] mm depth
- P_(A,B)** : 2xG1/2 - 15 [.59 in] mm depth
- T** : G1/4 - 10 mm [.393 in] depth

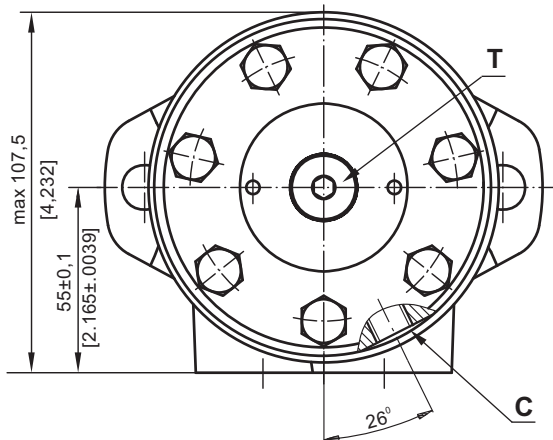

Type	L1, mm [in]	L2, mm [in]	L, mm [in]
B/MR 80	14,0 [.551]	205,5 [8.091]	213,5 [8.405]
B/MR 100	17,4 [.685]	209,0 [8.228]	217,0 [8.543]
B/MR 125	21,8 [.858]	213,5 [8.405]	221,5 [8.720]
B/MR 160	27,8 [1.095]	219,5 [8.642]	227,5 [8.957]
B/MR 200	34,8 [1.37]	226,5 [8.917]	234,5 [9.232]
B/MR 250	43,5 [1.713]	235,0 [9.252]	243,0 [9.567]
B/MR 315	54,8 [2.157]	246,5 [9.705]	254,5 [10.02]
B/MR 400	69,4 [2.732]	261,0 [10.275]	269,0 [10.59]

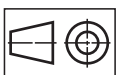

mm [in]

Standard Rotation
Viewed from Shaft End
Port A Pressurized - **CW**
Port B Pressurized - **CCW**

Reverse Rotation
Viewed from Shaft End
Port A Pressurized - **CCW**
Port B Pressurized - **CW**

SHAFT EXTENSIONS

C - $\varnothing 25$ straight, Parallel key A8x7x32 DIN 6885
Max. Torque 34 daNm [3010 lb-in]

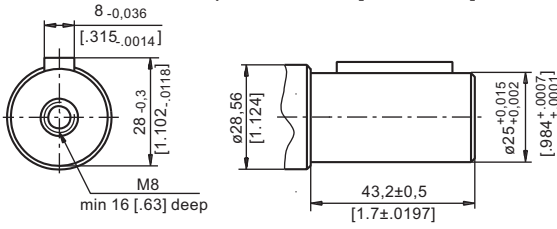

CO - $\varnothing 1"$ straight, Parallel key $\frac{1}{4}" \times \frac{1}{4}" \times 1\frac{1}{4}"$ BS46
Max. Torque 34 daNm [3010 lb-in]

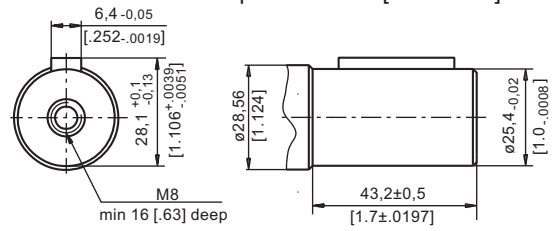

SH - splined, BS 2059 (SAE 6B)
Max. Torque 40 daNm [3540 lb-in]

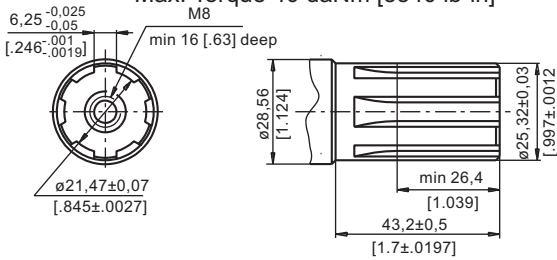

SA - splined, B25x22h9 DIN 5482
Max. Torque 40 daNm [3540 lb-in]

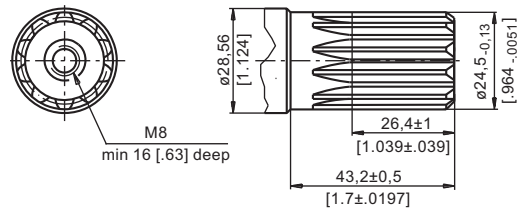

CB - $\varnothing 32$ straight, Parallel key A10x8x45 DIN 6885
Max. Torque 77 daNm [6815 lb-in]

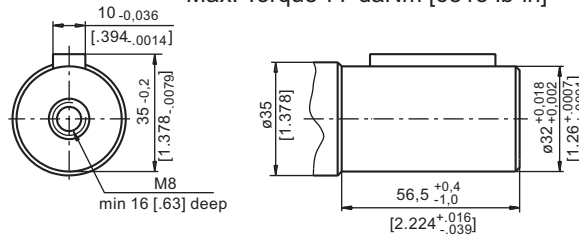

MOUNTING

Oval Mount (2 Holes)

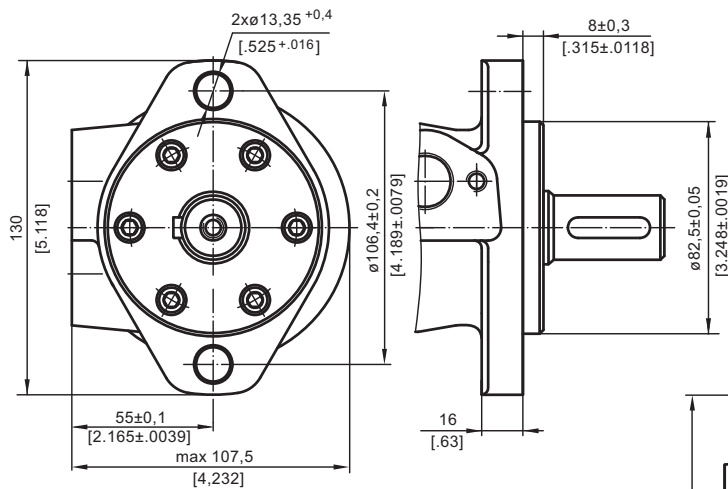

F - Oval Mount (4 Holes)

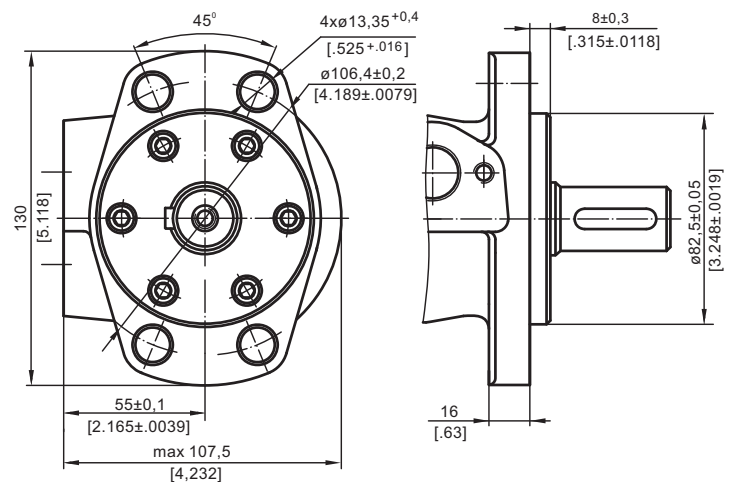

PERMISSIBLE SHAFT LOADS

The permissible radial shaft load P_{rad} depends on the speed n , RPM, distance L from the point of load to the mounting flange and shaft version.

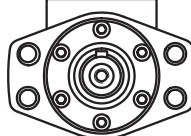
Mounting Flange		
Shaft Version	cylindrical - C, CO splined - SH, SA	cylindrical - CB
Radial Shaft Load P_{rad} , in mm	$\frac{800}{n} \times \frac{25000}{95+L}$, daN*	$\frac{800}{n} \times \frac{18750}{95+L}$, daN*
Radial Shaft Load P_{rad} , in inch	$\frac{800}{RPM} \times \frac{2215}{3.74+L}$, lbs*	$\frac{800}{RPM} \times \frac{1660}{3.74+L}$, lbs*

* $n \leq 200$ RPM; max P_{rad} =800 daN [1800 lbs] $n \geq 200$ RPM; $L < 55$ mm [2.2 in]

Radial Shaft Load P_{rad} for C, CO Shaft Extensions by $L=30$ mm [1.18 in]

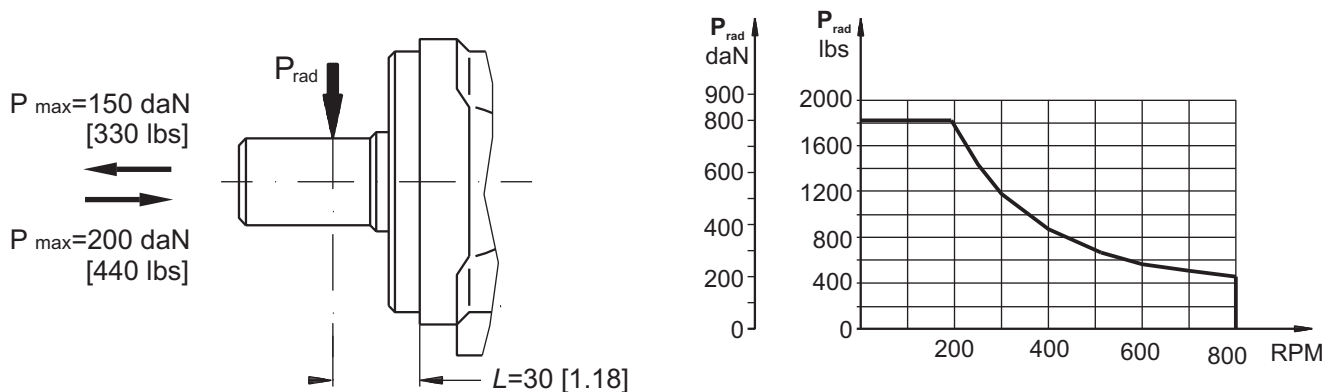

ORDER CODE

1	2	3	4	5
B / M R				

Pos.1 - Mounting Flange

- omit - Oval mount, two holes
- F** - Oval mount, four holes

Pos.2 - Displacement code

- 80** - 80,3 cm³/rev [4.90 in³/rev]
- 100** - 99,8 cm³/rev [6.09 in³/rev]
- 125** - 125,7 cm³/rev [7.67 in³/rev]
- 160** - 159,6 cm³/rev [9.74 in³/rev]
- 200** - 199,8 cm³/rev [12.19 in³/rev]
- 250** - 250,1 cm³/rev [15.26 in³/rev]
- 315** - 315,7 cm³/rev [19.26 in³/rev]
- 400** - 397,0 cm³/rev [24.40 in³/rev]

Pos.3 - Shaft Extensions*

- C** - $\varnothing 25$ straight, Parallel key A8x7x32 DIN6885
- CO** - $\varnothing 1$ " straight, Parallel key $\frac{1}{4}$ "x $\frac{1}{4}$ "x $1\frac{1}{4}$ " BS46
- SH** - $\varnothing 25,32$ splined BS 2059 (SAE 6B)
- SA** - $\varnothing 24,5$ splined B 25x22 DIN 5482
- CB** - $\varnothing 32$ straight, Parallel key A10x8x45 DIN 6885

Pos.4 - Special Features (see page 64)

Pos.5 - Design Series

- omit - Factory specified

NOTES:

* The permissible output torque for shafts must not be exceeded!

The motor-brakes are mangano-phosphatized as standard.

HYDRAULIC MOTOR-BRAKE MT/B



APPLICATION

- » Conveyors
- » Metal working machines
- » Agricultural machines
- » Road building machines
- » Mining machinery
- » Food industries
- » Special vehicles
- » Plastic and rubber machinery etc.

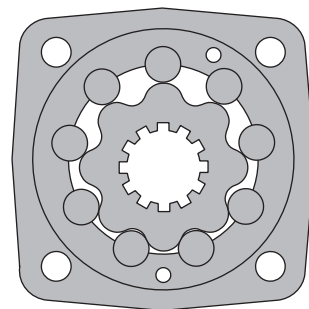

CONTENTS

Specification data	28
Dimensions and mounting	29
Permissible shaft loads	29
Shaft extensions	30
Order code	30

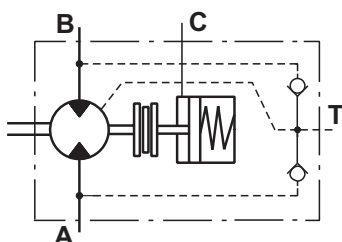

OPTIONS

- » Model - Disc valve, roll-gerotor;
- » Fully integrated friction disk brake;
- » Side ports;
- » Shafts - straight, splined and tapered;
- » BSPP ports
- » Other special features

GENERAL

Max. Displacement, cm ³ /rev [in ³ /rev]	523,6 [31.95]
Max. Speed, [RPM]	780
Max. Torque, daNm [lb-in]	cont.: 122 [10780] int.: 137 [12125]
Max. Output, kW [HP]	40 [54]
Max. Pressure Drop, bar [PSI]	cont.: 200 [2900] int.: 240 [3450]
Max. Oil Flow, lpm [GPM]	150 [40]
Min. Speed, [RPM]	5
Permissible Shaft Loads, daN [lbs]	P _a =1000 [2248]
Pressure fluid	Mineral based- HLP(DIN 51524) or HM(ISO 6743/4)
Temperature range, °C [°F]	-40÷140 [-40÷284]
Optimal Viscosity range, mm ² /s [SUS]	20÷75 [98÷347]
Filtration	ISO code 20/16 (Min. recommended fluid filtration of 25 microns)

Oil flow in drain line

Pressure drop bar [PSI]	Viscosity mm ² /s [SUS]	Oil flow in drain line lpm [GPM]
140 [2030]	20 [98]	2,5 [.66]
	35 [164]	1,5 [.39]
210 [3045]	20 [98]	5 [1.32]
	35 [164]	3 [.79]

Pressure Losses

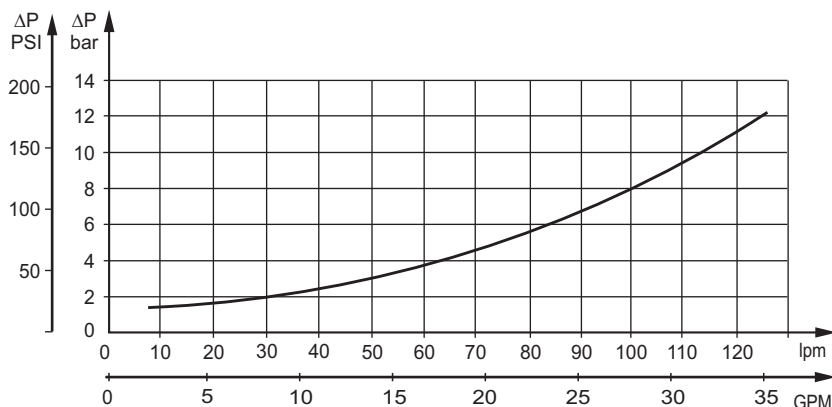

SPECIFICATION DATA

Type		MT/B 160	MT/B 200	MT/B 250	MT/B 315	MT/B 400	MT/B 500
Displacement, cm³/rev [in³/rev]		161,1 [9.83]	201,4 [12.29]	251,8 [15.36]	326,3 [19.90]	410,9 [25.06]	523,6 [31.95]
Max. Speed, [RPM]	Cont.	625	625	500	380	305	240
	Int.*	780	750	600	460	365	285
Max. Torque daNm [lb-in]	Cont.	47 [4160]	59 [5220]	73 [6460]	95 [8410]	108 [9560]	122 [10800]
	Int.*	56 [4960]	71 [6285]	88 [7790]	114 [10090]	126 [11150]	137 [12125]
Max. Output kW [HP]	Cont.	26,5 [36]	33,5 [45]	33,5 [45]	33,5 [45]	30 [40]	26,5 [36]
	Int.*	32 [43]	40 [54]	40 [54]	40 [54]	35 [45]	30 [40]
Max. Pressure Drop bar [PSI]	Cont.	200 [2900]	200 [2900]	200 [2900]	200 [2900]	180 [2600]	160 [2300]
	Int.*	240 [3450]	240 [3450]	240 [3450]	240 [3450]	210 [3050]	180 [2600]
Max. Oil Flow lpm [GPM]	Cont.	100 [26.5]	125 [33]	125 [33]	125 [33]	125 [33]	125 [33]
	Int.*	125 [33]	150 [40]	150 [40]	150 [40]	150 [40]	150 [40]
Max. Inlet Pressure bar [PSI]	Cont.	210 [3050]	210 [3050]	210 [3050]	210 [3050]	210 [3050]	210 [3050]
	Int.*	250 [3600]	250 [3600]	250 [3600]	250 [3600]	250 [3600]	250 [3600]
Max. Return Pressure with Drain Line, bar [PSI]	Cont.	140 [2030]	140 [2030]	140 [2030]	140 [2030]	140 [2030]	140 [2030]
	Int.*	175 [2540]	175 [2540]	175 [2540]	175 [2540]	175 [2540]	175 [2540]
Max. Starting Pressure with Unloaded Shaft, bar [PSI]		10 [150]	10 [150]	10 [150]	10 [150]	10 [150]	10 [150]
Min. Starting Torque daNm [lb-in]	At max. press. drop Cont.	34 [3010]	43 [3800]	53 [4690]	74 [6550]	84 [7435]	95 [8410]
	At max. press. drop Int.*	41 [3630]	52 [4600]	63 [5580]	89 [7880]	97 [8585]	106 [9380]
Min. Speed**, [RPM]		10	9	8	7	6	5
Static Torque of Brake, daNm [lb-in]		143 [12657]	143 [12657]	143 [12657]	143 [12657]	143 [12657]	143 [12657]
Min. Brake Release Pressure***, bar [PSI]		32-35 [2832-3098]	32-35 [2832-3098]	32-35 [2832-3098]	32-35 [2832-3098]	32-35 [2832-3098]	32-35 [2832-3098]
Max. Opening Pressure, bar [PSI]		280 [24782]	280 [24782]	280 [24782]	280 [24782]	280 [24782]	280 [24782]
Max. Pressure in Drain Line, bar [PSI]		5 [73]	5 [73]	5 [73]	5 [73]	5 [73]	5 [73]
Weight, kg [lb]		27,5 [60.6]	28 [61.7]	28,5 [62.8]	29,5 [65]	30,5 [67.2]	31,5 [69.4]

* Intermittent operation: the permissible values may occur for max. 10% of every minute.

** For speeds lower than given, consult factory or your regional manager.

*** Motor-brakes must always have a drain line. The brake release pressure is the difference between the pressure in the brake release line and the pressure in the drain line.

- Intermittent speed and intermittent pressure must not occur simultaneously.
- Recommended filtration is per ISO cleanliness code 20/16. A nominal filtration of 25 micron or better.
- Recommend using a premium quality, anti-wear type mineral based hydraulic oil HLP(DIN51524) or HM (ISO 6743/4).
If using synthetic fluids consult the factory for alternative seal materials.
- Recommended minimum oil viscosity 13 mm²/s [70 SUS] at 50°C [122°F].
- Recommended maximum system operating temperature is 82°C [180°F].
- To assure optimum motor life fill with fluid prior to loading and run at moderate load and speed for 10-15 minutes.

DIMENSIONS AND MOUNTING DATA

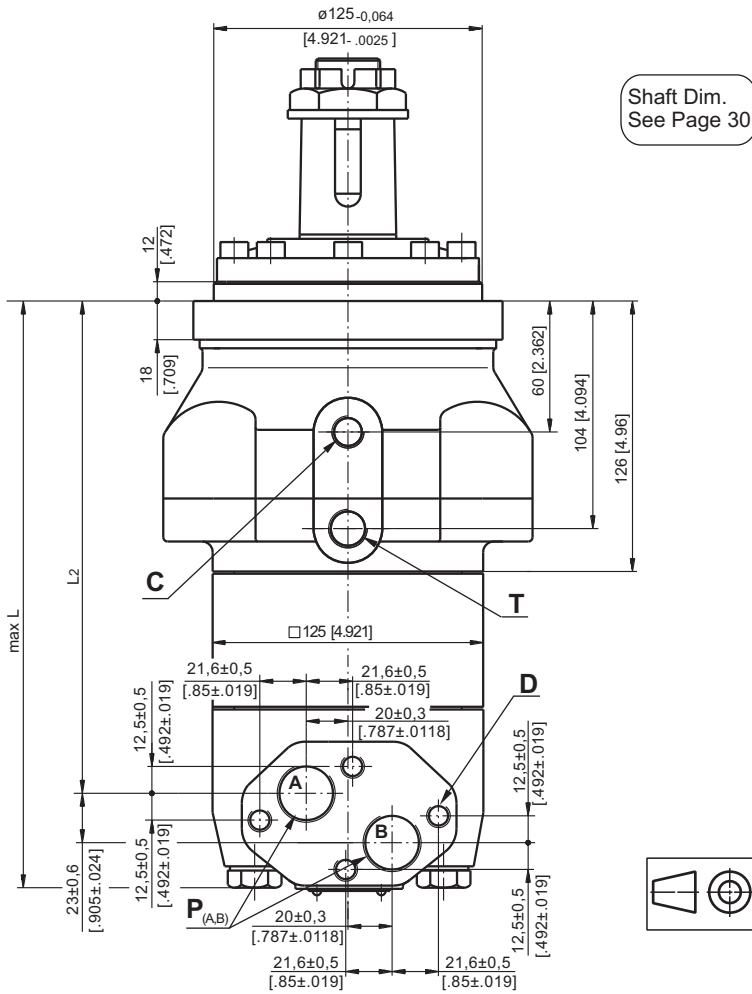

Standard Rotation
Viewed from Shaft End
Port A Pressurized - CW
Port B Pressurized - CCW

Reverse Rotation
Viewed from Shaft End
Port A Pressurized - CCW
Port B Pressurized - CW

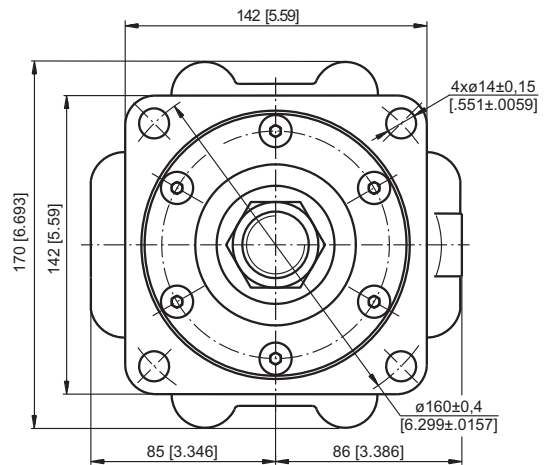
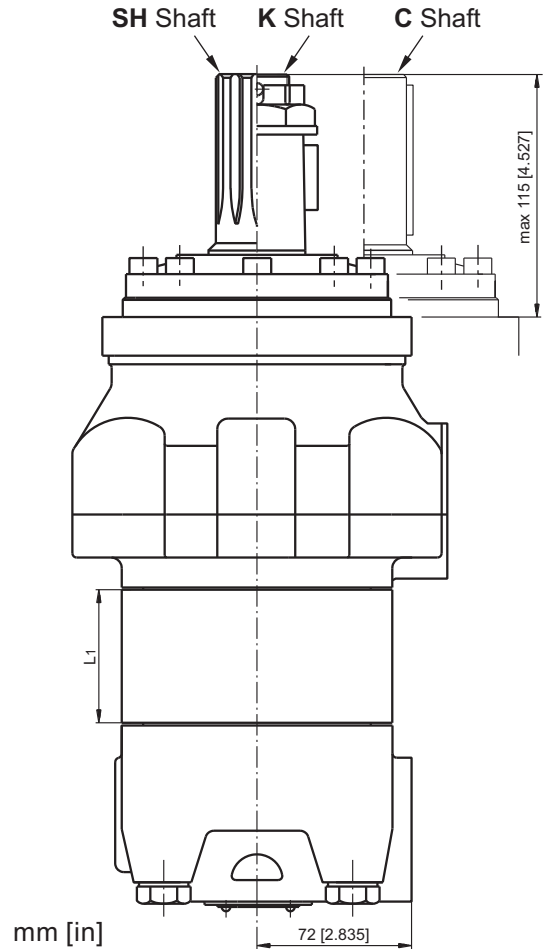

- P_(A,B)** - 2xG3/4, 17 mm [.669] depth
- C** - Brake release port, G1/4, 12 mm [.472] depth
- T** - Drainage tap, G3/8, 13 mm [.512] depth
- D** - 4xM10, 10 mm [.394] depth

Type	*L1,mm [in]	L2,mm [in]	L,mm [in]
MT/B 160	16,5 [.65]	178 [7.01]	228 [8.98]
MT/B 200	21,5 [.85]	183 [7.21]	233 [9.17]
MT/B 250	27,8 [1.09]	189,3 [7.45]	239 [9.41]
MT/B 315	37,0 [1.46]	198,5 [7.81]	248 [9.76]
MT/B 400	47,5 [1.87]	209 [8.23]	259 [10.2]
MT/B 500	61,5 [2.42]	223 [8.78]	273 [10.8]

* The width of the gerotor is 3,5 mm [.138 in] greater than L₁.

PERMISSIBLE SHAFT LOADS

The curve applies to a B10 bearing life of 3000 hours at 200 RPM.
Max. permissible radial shaft load with a safety factor of 3:1.

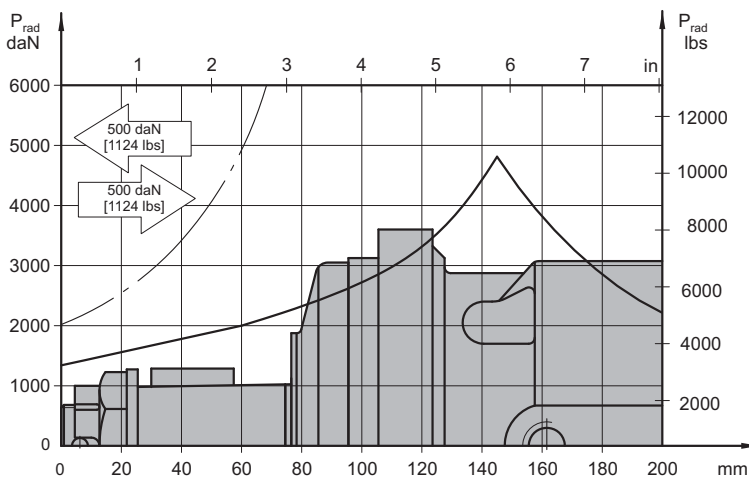

SHAFT EXTENSIONS

C - ϕ 40 straight, Parallel key A12x8x70 DIN 6885
Max. Torque 123 daNm [10886 lb-in]

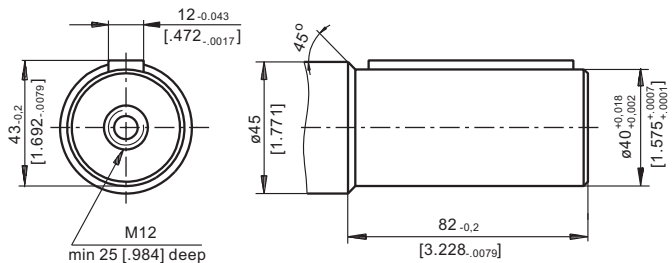

SH - ϕ 1½" splined 17T, DP 12/24 ANSI B92.1-1976
Max. Torque 123 daNm [10886 lb-in]

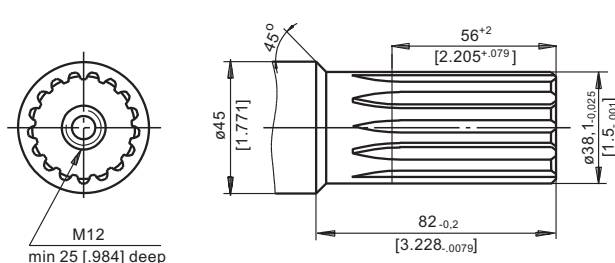

K -tapered 1:10, Parallel key B12x8x28 DIN 6885
Max. Torque 210 daNm [18587 lb-in]

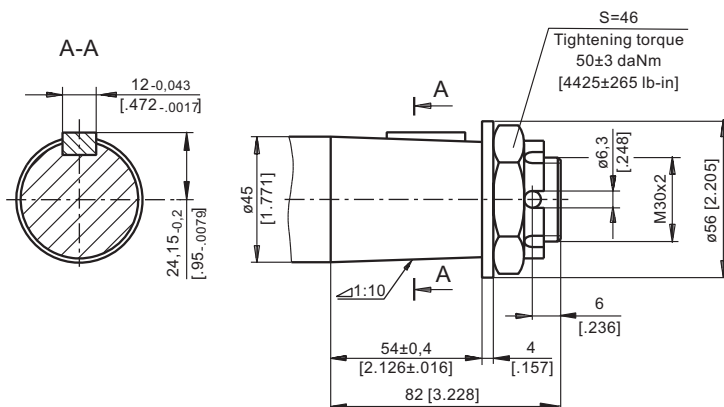

ORDER CODE

	1	2	3	4
MT/B				

Pos.1 - Displacement code

160	- 161,1 cm ³ /rev [9.83 in ³ /rev]
200	- 201,4 cm ³ /rev [12.29 in ³ /rev]
250	- 251,8 cm ³ /rev [15.36 in ³ /rev]
315	- 326,3 cm ³ /rev [19.90 in ³ /rev]
400	- 410,9 cm ³ /rev [25.06 in ³ /rev]
500	- 523,6 cm ³ /rev [31.95 in ³ /rev]

Pos.2 - Shaft Extensions**

C	- ϕ 40 straight, Parallel key A12x8x70 DIN6885
SH	- ϕ 1½" splined 17 DP12/24 ANS B922.1-76
K	- ϕ 45 tapered 1:10, Parallel key B12x8x28 DIN 6885

Pos.3 - Special Features (see page 64)

Pos.4 - Design Series

omit - Factory specified

NOTES:

* The permissible output torque for shafts must not be exceeded!

The motor-brakes are manganese-phosphatized as standard.

HYDRAULIC MOTOR-BRAKE MTM/B



APPLICATION

- » Skid Steer Loaders
- » Metal working machines
- » Trenchers
- » Augers
- » Agricultural machines
- » Road building machines
- » Special vehicles
- » Mine machines
- » Woodworking and sawmill machinery
- » Conveyors etc.

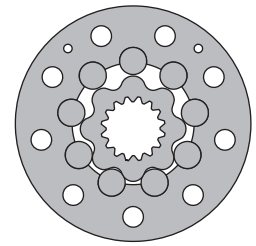

CONTENTS

Specification data	32
Dimensions and mounting ..	33+34
Shaft extensions	35
Permissible shaft loads	36
Order code	36

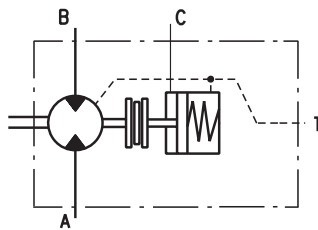

OPTIONS

- » Model - Disc valve, roll-gerotor;
- » Fully integrated friction disk brake;
- » Side ports;
- » Shafts - straight, splined and tapered;
- » BSPP ports
- » Other special features

GENERAL

Max. Displacement, cm ³ /rev [in ³ /rev]	724,3 [44.2]
Max. Speed, [RPM]	750
Max. Torque, daNm [in-lb]	cont.: 175 [15490] int.: 215 [16030]
Max. Output, kW [HP]	70 [94]
Max. Pressure Drop, bar [PSI]	cont.: 250 [3600] int.: 350 [5080]
Max. Oil Flow, lpm [GPM]	150 [40]
Permissible Shaft Loads daN [lbs]	P _a =1000 [2250]
Pressure fluid	Mineral based- HLP(DIN 51524) or HM(ISO 6743/4)
Temperature range, °C [°F]	-40÷140 [-40÷284]
Optimal Viscosity range, mm ² /s [SUS]	20÷75 [98÷347]
Filtration	ISO code 20/16 (Min. recommended fluid filtration of 25 microns)

Oil flow in drain line

Pressure drop bar [PSI]	Viscosity mm ² /s [SUS]	Oil flow in drain line lpm [GPM]
200 [2900]	20 [98]	2,5 [.660]
	35 [164]	1,5 [.400]
275 [3990]	20 [98]	4 [1.057]
	35 [164]	2,5 [.660]

Pressure Losses

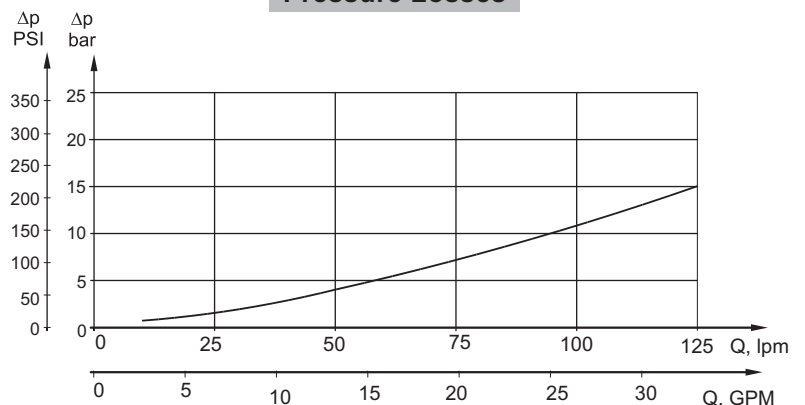

SPECIFICATION DATA

Type	MTM/B 200	MTM/B 250	MTM/B 315	MTM/B 400	MTM/B 470	MTM/B 500	MTM/B 630	MTM/B 725	
Displacement, cm³/rev [in³/rev]	201,4 [12.29]	251,8 [15.36]	326,3 [19.9]	410,9 [25.06]	475 [28.97]	494,9 [30.17]	631,2 [38.5]	724 [44.2]	
Max. Speed, [RPM]	Cont.	625	500	380	305	260	250	196	170
	Int.*	750	600	460	365	315	300	235	215
Max. Torque, daNm [lb-in]	Cont.	72 [6375]	90 [7965]	116 [10265]	147 [13010]	171 [15135]	172 [15225]	175 [15490]	160 [14160]
	Int.*	102 [9030]	128 [11330]	163 [14425]	206 [18232]	215 [16030]	215 [16030]	215 [16030]	192 [17000]
	Peak**	115 [10180]	144 [12745]	186 [16460]	235 [20800]	240 [21240]	240 [21240]	255 [22570]	240 [21240]
Max. Output, kW [HP]	Cont.	41 [55]	41 [55]	41 [55]	41 [55]	41 [55]	37,5 [50]	29 [39]	26 [35]
	Int.*	65 [87]	70 [94]	70 [94]	70 [94]	55 [74]	51 [68]	45 [60]	40 [54]
Max. Pressure Drop, bar [PSI]	Cont.	250 [3600]	250 [3600]	250 [3600]	250 [3600]	250 [3600]	230 [3340]	185 [2680]	160 [2320]
	Int.*	350 [5080]	350 [5080]	350 [5080]	350 [5080]	315 [4570]	280 [4060]	225 [3260]	210 [3045]
	Peak**	400 [5800]	400 [5800]	400 [5800]	400 [5800]	350 [5080]	320 [4640]	270 [3985]	260 [3770]
Max. Oil Flow, lpm [GPM]	Cont.	125 [33]	125 [33]	125 [33]	125 [33]	125 [33]	125 [33]	125 [33]	125 [33]
	Int.*	150 [40]	150 [40]	150 [40]	150 [40]	150 [40]	150 [40]	150 [40]	150 [40]
Max. Starting Pressure with Unloaded Shaft, bar [PSI]	6 [87]	6 [87]	6 [87]	6 [87]	6 [87]	6 [87]	6 [87]	6 [87]	
Min. Starting Torque, daNm [lb-in]	60 [5310]	75 [6640]	97 [8585]	122 [10800]	142 [12570]	143 [12655]	144 [12745]	148 [13100]	
Static Torque of Brake, daNm [lb-in]	200 [17700]								
Min. Brake Release Pressure***, bar [PSI]	14 [203]								
Full Opening Pressure, bar [PSI]	40 [580]								
Max. Pressure in Release Port C, bar [PSI]	120 [1740]								
Weight, kg [lb]	37,5 [82.7]	37,9 [83.6]	39,1 [86.2]	41,3 [91.1]	44,1 [97.2]	46,0 [101.4]	49,1 [108.2]	52,0 [114.6]	

* Intermittent operation: the permissible values may occur for max. 10% of every minute.

** Peak load: the permissible values may occur for max. 1% of every minute.

*** Motor-brakes must always have a drain line. The brake release pressure is the difference between the pressure in the brake release line and the pressure in the drain line.

1. Intermittent speed and intermittent pressure drop must not occur simultaneously.
2. Recommended filtration is per ISO cleanliness code 20/16. A nominal filtration of 25 micron or better.
3. Recommend using a premium quality, anti-wear type mineral based hydraulic oil HLP(DIN51524) or HM (ISO 6743/4).
If using synthetic fluids consult the factory for alternative seal materials.
4. Recommended minimum oil viscosity 13 mm²/s [70 SUS] at 50°C [122°F].
5. Recommended maximum system operating temperature is 82°C [180°F].
6. To assure optimum motor life fill with fluid prior to loading and run at moderate load and speed for 10-15 minutes.

DIMENSIONS AND MOUNTING DATA - MTM/B D

D - Bolt flange 4xø18.5 mm
spigot diameter 7.086 in [ø180 mm]

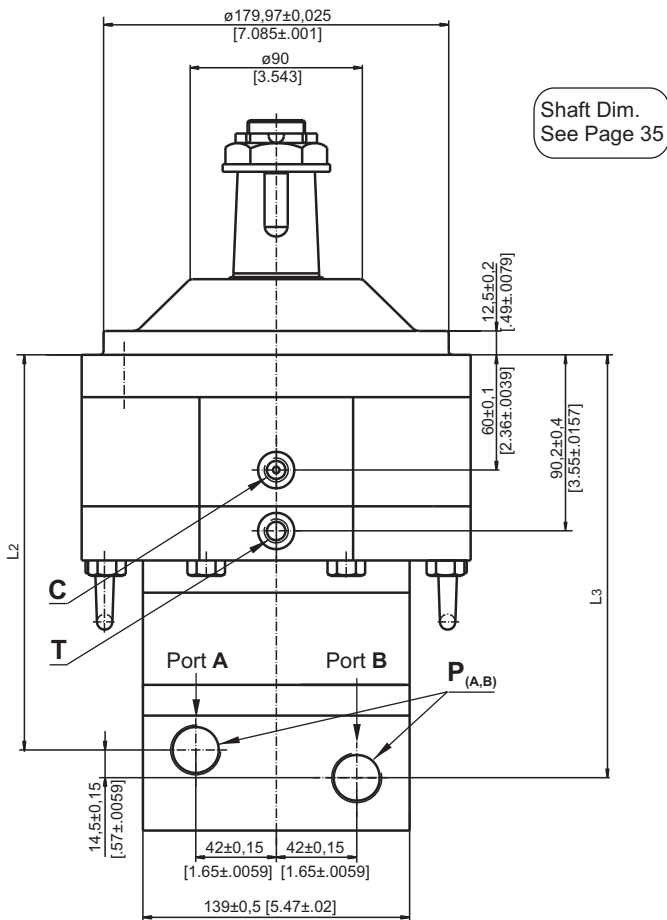

Shaft Dim.
See Page 35

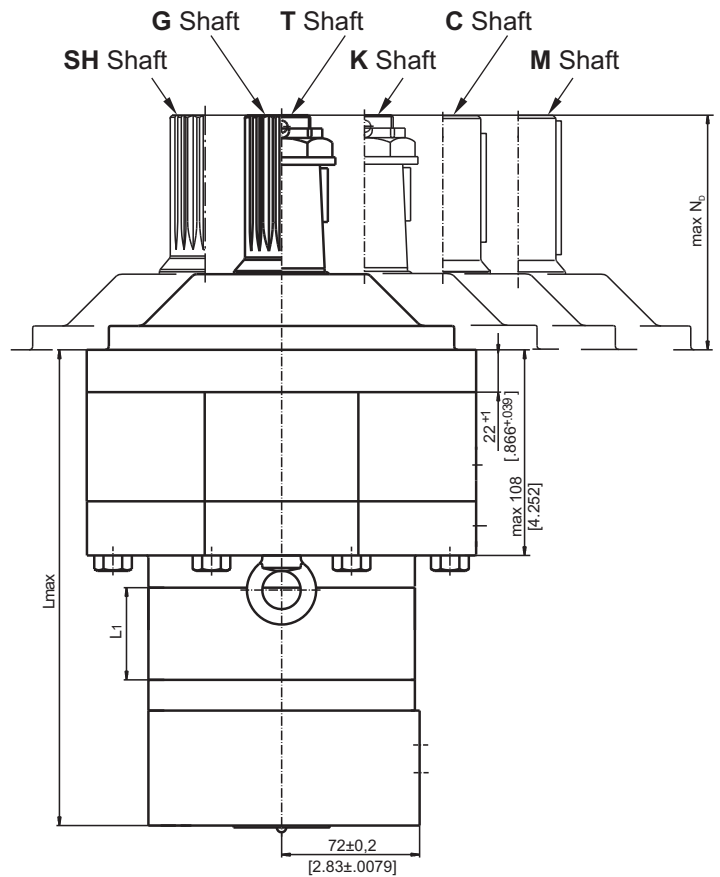

Standard Rotation
Viewed from Shaft End
Port **A** Pressurized - **CW**
Port **B** Pressurized - **CCW**

Reverse Rotation
Viewed from Shaft End
Port **A** Pressurized - **CCW**
Port **B** Pressurized - **CW**

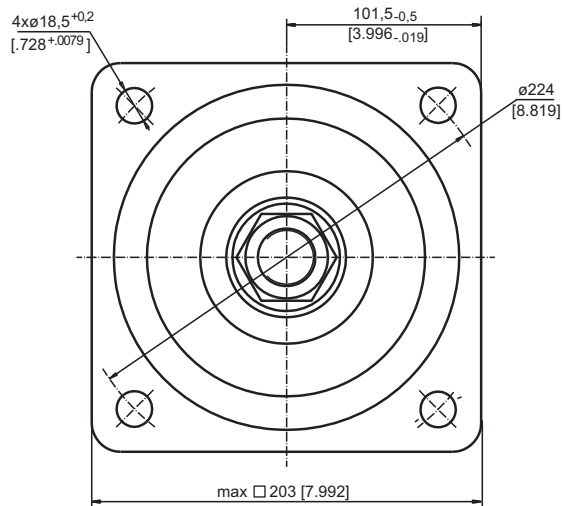

Type	L, mm [in]	L2, mm [in]	L3, mm [in]	L1, mm [in]
MTM/B D 200	226 [8.90]	184 [7.24]	198,5 [7.86]	25 [.98]
MTM/B D 250	232,5 [9.15]	190 [7.48]	204,5 [8.05]	31,3 [1.23]
MTM/B D 315	241,5 [9.51]	199,5 [7.85]	214 [8.43]	40,5 [1.59]
MTM/B D 400	252 [9.92]	210 [8.27]	224,5 [8.84]	51 [2.01]
MTM/B D 470	260 [10.24]	218 [8.58]	232,5 [9.15]	59 [2.32]
MTM/B D 500	249 [9.80]	207 [8.15]	221,5 [8.72]	48 [1.89]
MTM/B D 630	262 [10.32]	220 [8.66]	234,5 [9.23]	61 [2.40]
MTM/B D 725	271 [10.67]	229 [9.02]	243,5 [9.59]	70 [2.76]

Note: For N_b see page 35

C : Brake release port
D : Drainage tap

	Versions	
	2	4
P (A,B)	2xG ³ / ₄	2x1 ¹ / ₁₆ -12UN
T	G ¹ / ₄	⁹ / ₁₆ -18UNF
C	G ¹ / ₄	⁷ / ₁₆ -20 UNF

DIMENSIONS AND MOUNTING DATA MTM/B C and MTM/B AC

C - Thread hole flange 4xM16
spigot diameter 125 mm [4.921 in]

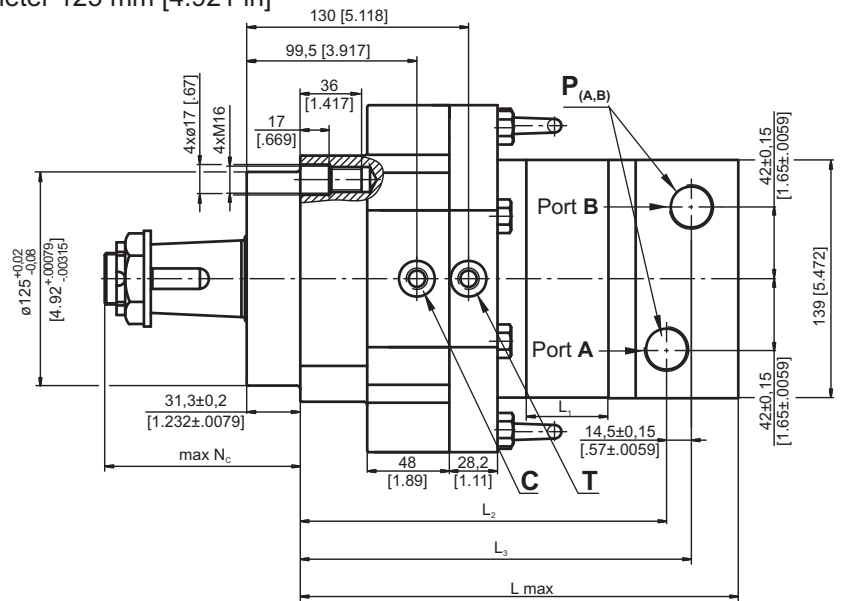
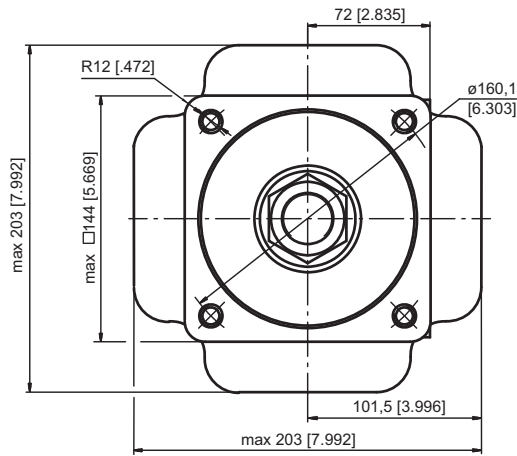

Shaft Dim.
See Page 35

AC - Thread hole flange 4x5/8-18 UNF
spigot diameter 127 mm [5.0 in]

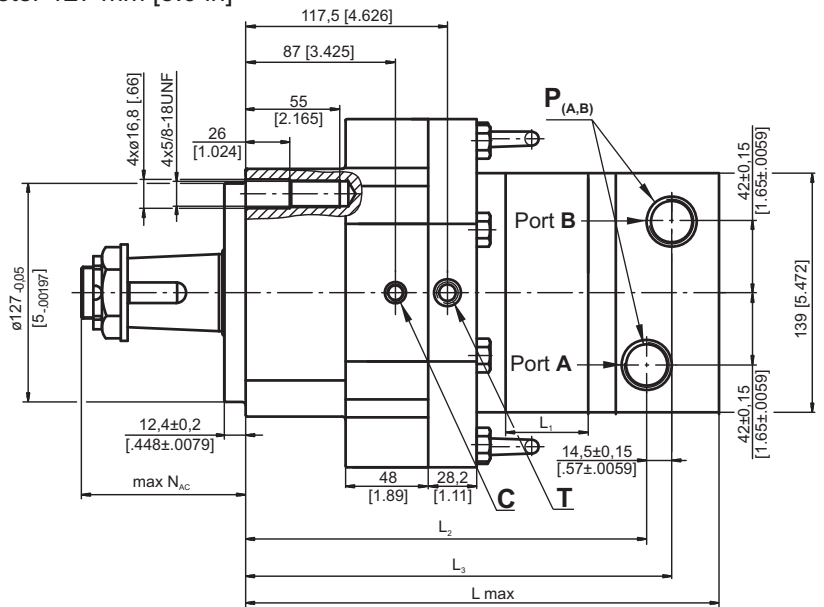
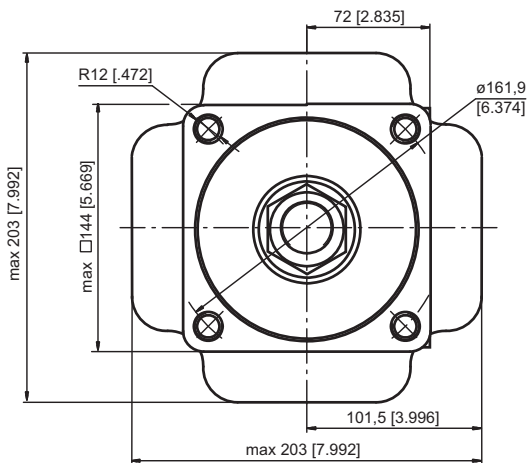

C : Brake release port
D : Drainage tap

	Versions	
	2	4
P (A,B)	2xG ³ / ₄	2x1 ¹ / ₁₆ -12UN
T	G ¹ / ₄	9 ¹ / ₁₆ -18UNF
C	G ¹ / ₄	7 ¹ / ₁₆ -20 UNF

Note: For N_C and N_{AC} see page 35

Standard Rotation
Viewed from Shaft End
Port A Pressurized - **CW**
Port B Pressurized - **CCW**

Reverse Rotation
Viewed from Shaft End
Port A Pressurized - **CCW**
Port B Pressurized - **CW**



Type	L, mm [in]	L2, mm [in]	L3, mm [in]	Type	L, mm [in]	L2, mm [in]	L3, mm [in]	L1, mm [in]
MTM/B C 200	233 [9.17]	191 [7.92]	205,5 [8.09]	MTM/B AC 200	252 [9.92]	210 [8.27]	224,5 [8.84]	25 [.98]
MTM/B C 250	239,3 [9.42]	197,3 [7.77]	211,8 [8.34]	MTM/B AC 250	258,5 [10.18]	216,5 [8.25]	231 [9.09]	31,3 [1.23]
MTM/B C 315	248,5 [9.48]	206,5 [8.13]	221 [8.70]	MTM/B AC 315	267,5 [10.53]	225,5 [8.88]	240 [9.45]	40,5 [1.59]
MTM/B C 400	259 [10.19]	217 [8.54]	231,5 [9.11]	MTM/B AC 400	278 [10.94]	236 [9.29]	250,5 [9.186]	51 [2.01]
MTM/B C 470	267 [10.51]	225 [8.86]	239,5 [9.43]	MTM/B AC 470	286 [11.26]	244 [9.61]	258,5 [10.18]	59 [2.32]
MTM/B C 500	256 [10.08]	214 [8.43]	228,5 [8.99]	MTM/B AC 500	275 [10.83]	233 [9.17]	247,5 [9.74]	48 [1.89]
MTM/B C 630	269 [10.59]	227 [8.94]	241,5 [9.51]	MTM/B AC 630	288 [11.34]	246 [9.68]	260,5 [10.26]	61 [2.40]
MTM/B C 725	278 [10.94]	236 [9.29]	250,5 [9.86]	MTM/B AC 725	297 [11.69]	255 [10.04]	269,5 [10.61]	70 [2.76]

SHAFT EXTENSIONS

C

1½" [38,1] sraight, Parallel key ¾"x ¾"x 2¼" BS46
Max. Torque 133 daNm [11770 lb-in]

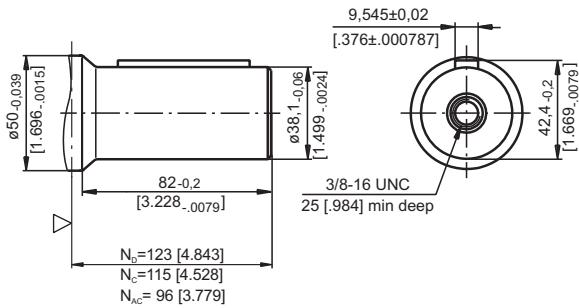

M

ø40 sraight, Parallel key A12x8x70
Max. Torque 133 daNm [11770 lb-in]

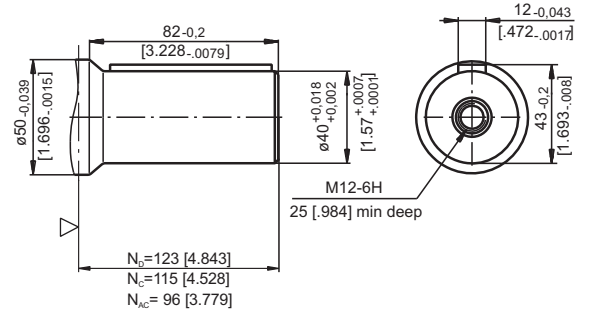

G

17T Splined, 1½" [38,1] ANS B92.1-1976
Max. Torque 210 daNm [18580 lb-in]

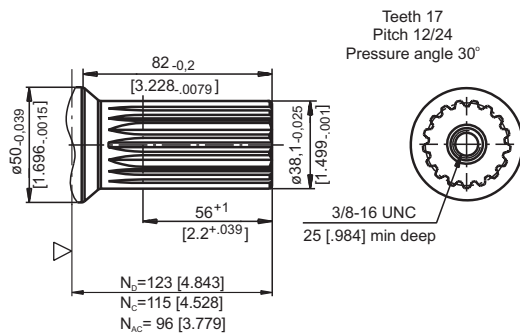

T

1¾" [44,5] SAE J501 Tapered 1:8
Parallel key 7/16"x 1¼" BS46
Max. Torque 210 daNm [18580 lb-in]

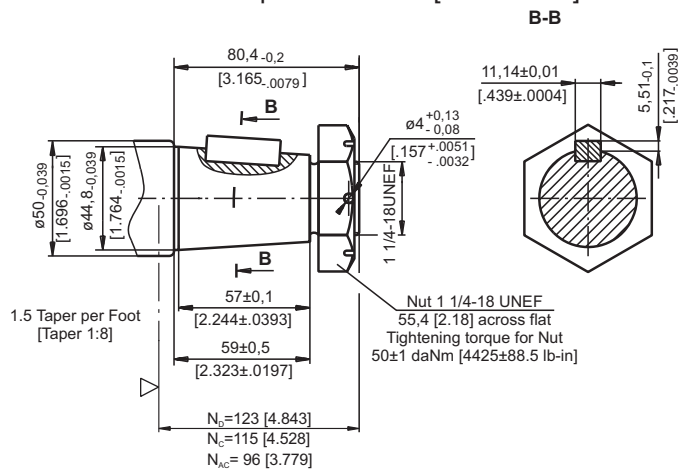

SH

17T Splined, 1½" [38,1] ANS B92.1-1976
Max. Torque 210 daNm [18580 lb-in]

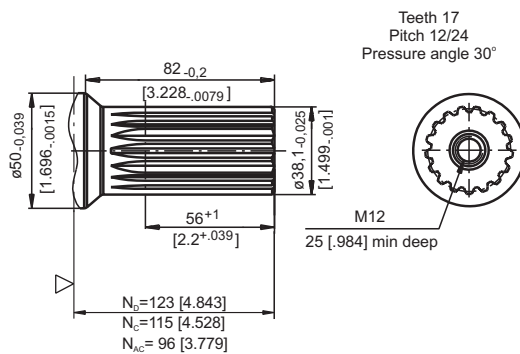

K

ø45 Tapered 1:10
Parallel key 12x8x28 DIN 6885
Max. Torque 210 daNm [18580 lb-in]

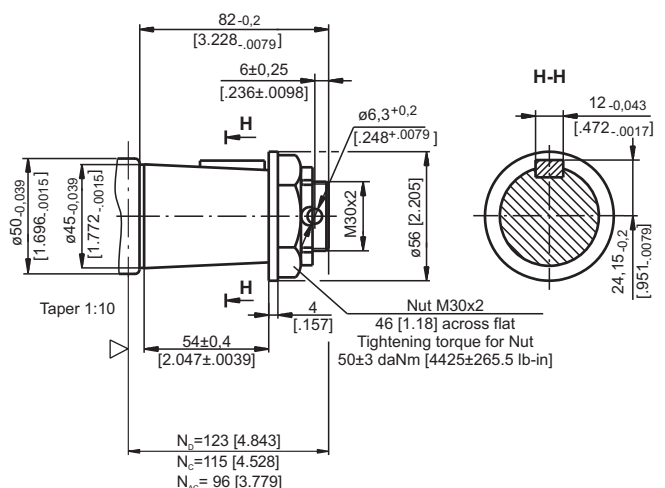

▽ - Motor Mounting Surface

N_D - for D flange
 N_C - for C flange
 N_{AC} - for AC flange

mm [in]

PERMISSIBLE RADIAL SHAFT LOADS

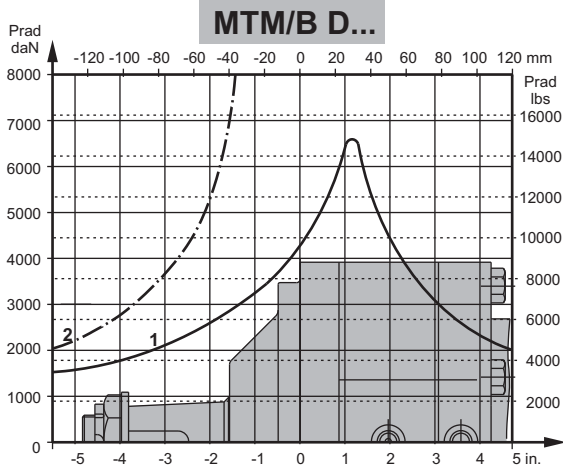

- 1 - Bearing curve: The curve applies to a B10 bearing life of 2000 hours at 100 RPM.
- 2 - Shaft curve: The curve represents Max. permissible radial shaft load with safety factor 2:1.

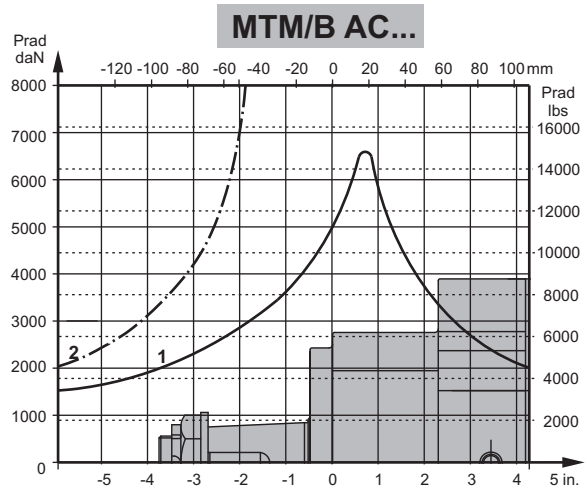
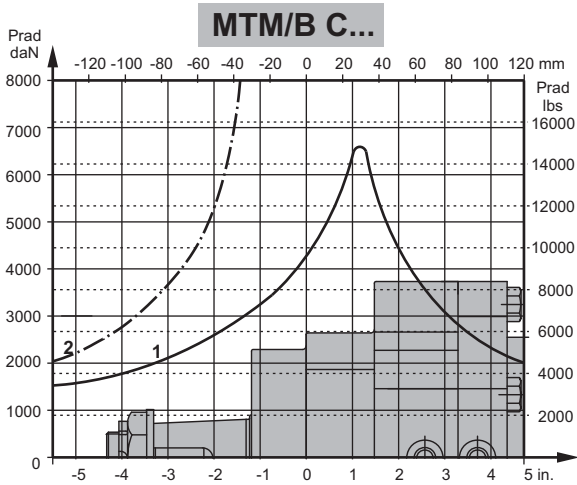

ORDER CODE

	1	2	3	4	5	6
MTM/B						

Pos.1 - Mounting Flange

- AC** - Flange 4x5/8-18UNC, spigot dia. \varnothing 127 mm [5 in]
- C** - Flange 4xM16, spigot dia. \varnothing 125 mm [4.92 in]
- D** - Flange 4x \varnothing 18,5 [.73], spigot dia. \varnothing 180 mm [7.09 in]

Pos.2 - Displacement code

- 200** - 201,4 cm³/rev [12.29 in³/rev]
- 250** - 251,8 cm³/rev [15.36 in³/rev]
- 315** - 326,3 cm³/rev [19.90 in³/rev]
- 400** - 410,9 cm³/rev [25.06 in³/rev]
- 470** - 475,0 cm³/rev [28.97 in³/rev]
- 500** - 523,6 cm³/rev [31.95 in³/rev]
- 630** - 631,2 cm³/rev [38.52 in³/rev]
- 725** - 724,3 cm³/rev [44.20 in³/rev]

Pos.3 - Shaft Extensions*

- C** - 1½" [38,1] straight, Parallel key 3/8x3/8x2 1/4"
- G** - 1½" [38,1] 17T Splined (3/8-16 UNC)
- M** - 40 mm straight, Parallel key 12x8x70
- T** - 1:8 Tapered, Parallel key 7/16x7/16x1 1/4"
- SH** - 1½" [38,1] 17T Splined (M12)
- K** - 1:10 Tapered, Parallel key 12x8x28

Pos.4 - Port Size/Type

- 2** - side ports, 2xG 3/4, G1/4, BSP thread, ISO 228
- 4** - side ports, 2x1 1/16-12 UN, O-ring, 9/16-18 UNF, 7/16-20UNF

Pos.5 - Special Features

- omit - Reinforced motor **HD**** (always)
- For Other **Special Features** see page 64

Pos.6 - Design Series

- omit - Factory specified

Notes:

- * The permissible output torque for shafts must not be exceeded!
- ** The drain line must always be opened!

The motor-brakes are mangano-phosphatized as standard.

HYDRAULIC MOTOR-BRAKES SW500B350V



APPLICATION

- » Wheel drives
- » Conveyors
- » Rotators
- » Positioners
- » Winches
- » Swing drives
- » Door openers

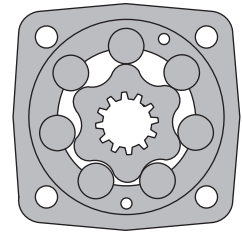

CONTENTS

Specification data	37
Dimensions and mounting	38
Permissible shaft loads	38
Function diagrams	39
Order code	39

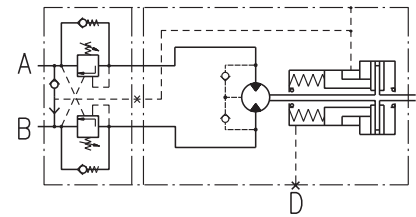

SPECIFICATION DATA

Type	SW500B350V
Displacement, cm³/rev [in³/rev]	475,3 [29]
Max. Speed, RPM	16
Cont.	
Int.*	25
Max. Torque, daNm [lb-in]	82 [7260]
Cont.	
Int.*	95 [8420]
Max. Output, kW [HP]	0,9 [1.3]
Cont.	
Int.*	2,4 [3.3]
Max. Pressure Drop, bar [PSI]	125 [1800]
Cont.	
Int.*	145 [2100]
Max. Oil Flow, lpm [GPM]	8 [2]
Cont.	
Int.*	12 [3]
Max. Return Pressure without Drain Line or Max. Pressure in Drain Line, bar [PSI]	100 [1450]
Min. Starting Torque, daNm [lb-in]	72 [6400]
At max. press. drop Cont.	
At max. press. drop Int.*	75 [6650]
Min. Speed**, RPM	5
Static Torque for the Brake***, daNm [lb-in]	164 [14 515]
Release Pressure ±10%, bar [PSI]	25...28 [363...406]
initial	
full	31 [449.6]
Max. Steering Pressure, bar [PSI]	245 [3553]
Max. Pressure in Drain Space for the Brake, bar [PSI]	0,5 [7]
Pilot Ratio for the Valve	4,25:1

* Intermittent operation: the permissible values may occur for max. 10% of every minute.

** For speeds of 5 RPM lower than given, consult factory or your regional manager.

*** Static torque is obtained at working pressure - 0 PSI [0 bar].

Space is filled with 125±20 cm³ [7.63±1.22 in³] mineral oil HLP (DIN 51524) or HM (ISO 6743/4).

DIMENSIONS AND MOUNTING

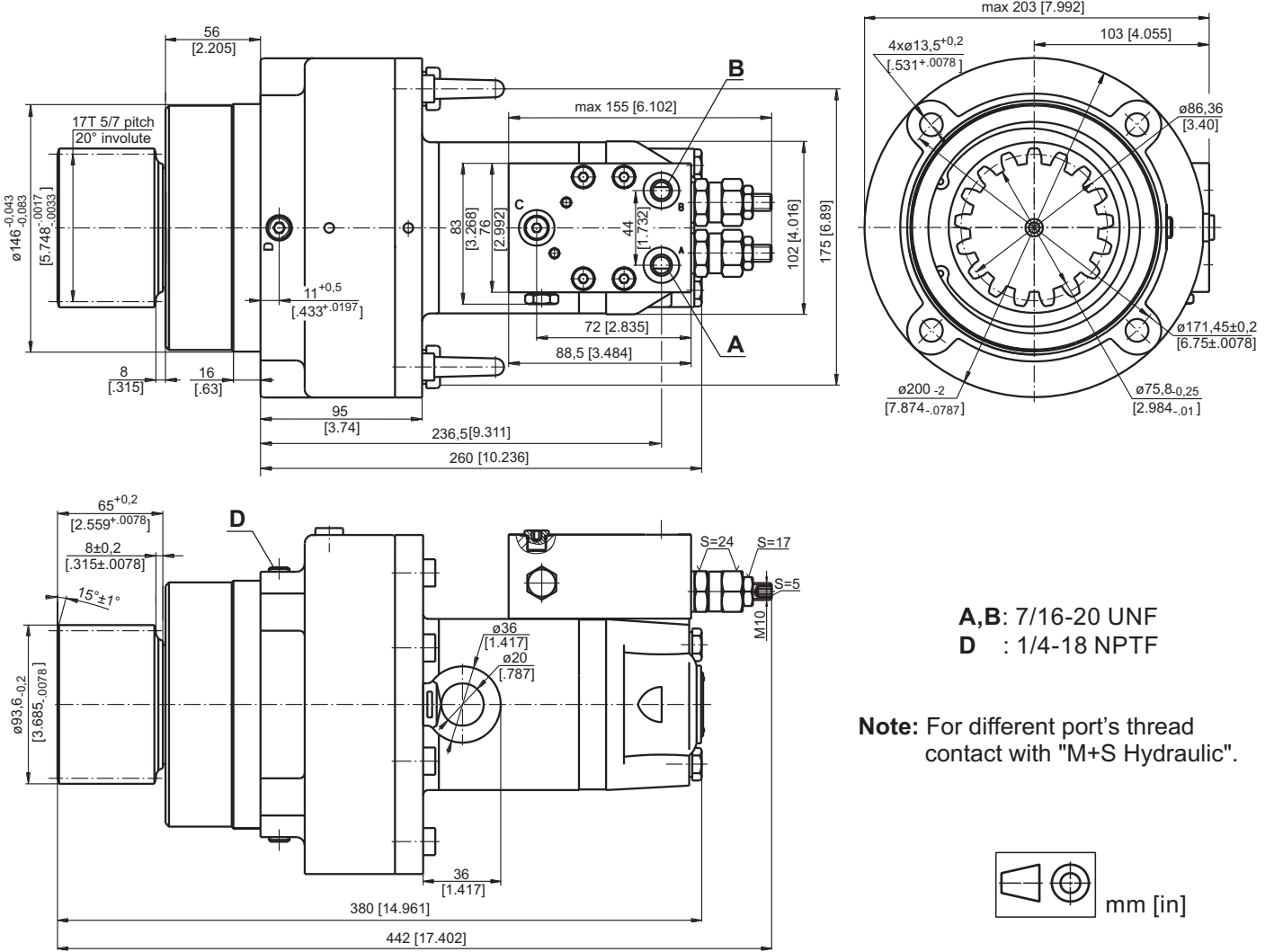

PERMISSIBLE SHAFT LOADS

The curve applies to a B10 bearing life of 3000 hours at 40 RPM.

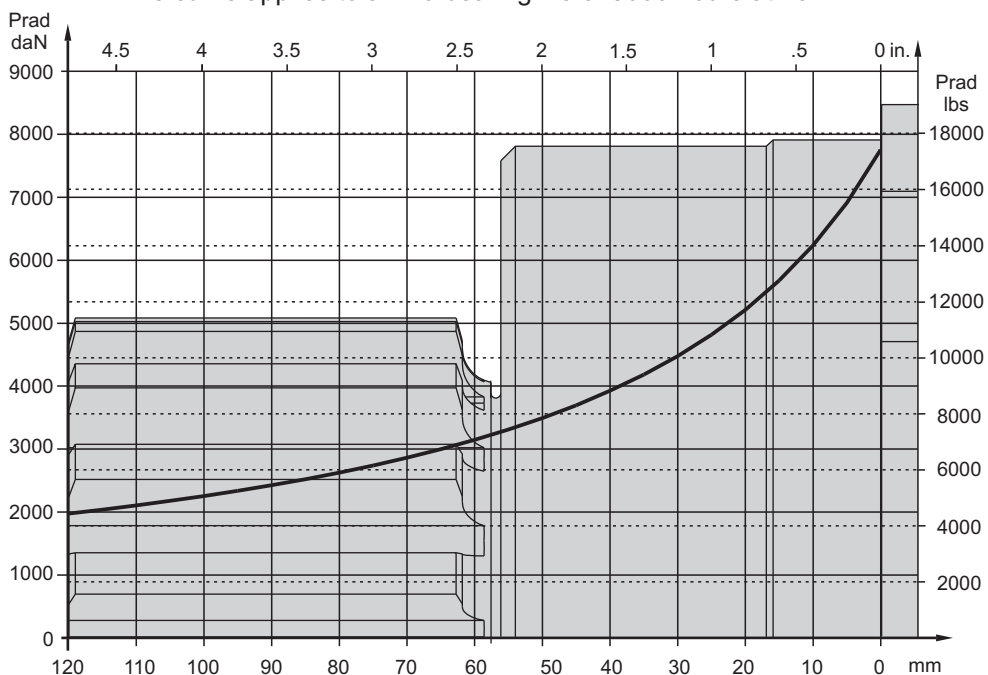

FUNCTION DIAGRAMS

SW 500

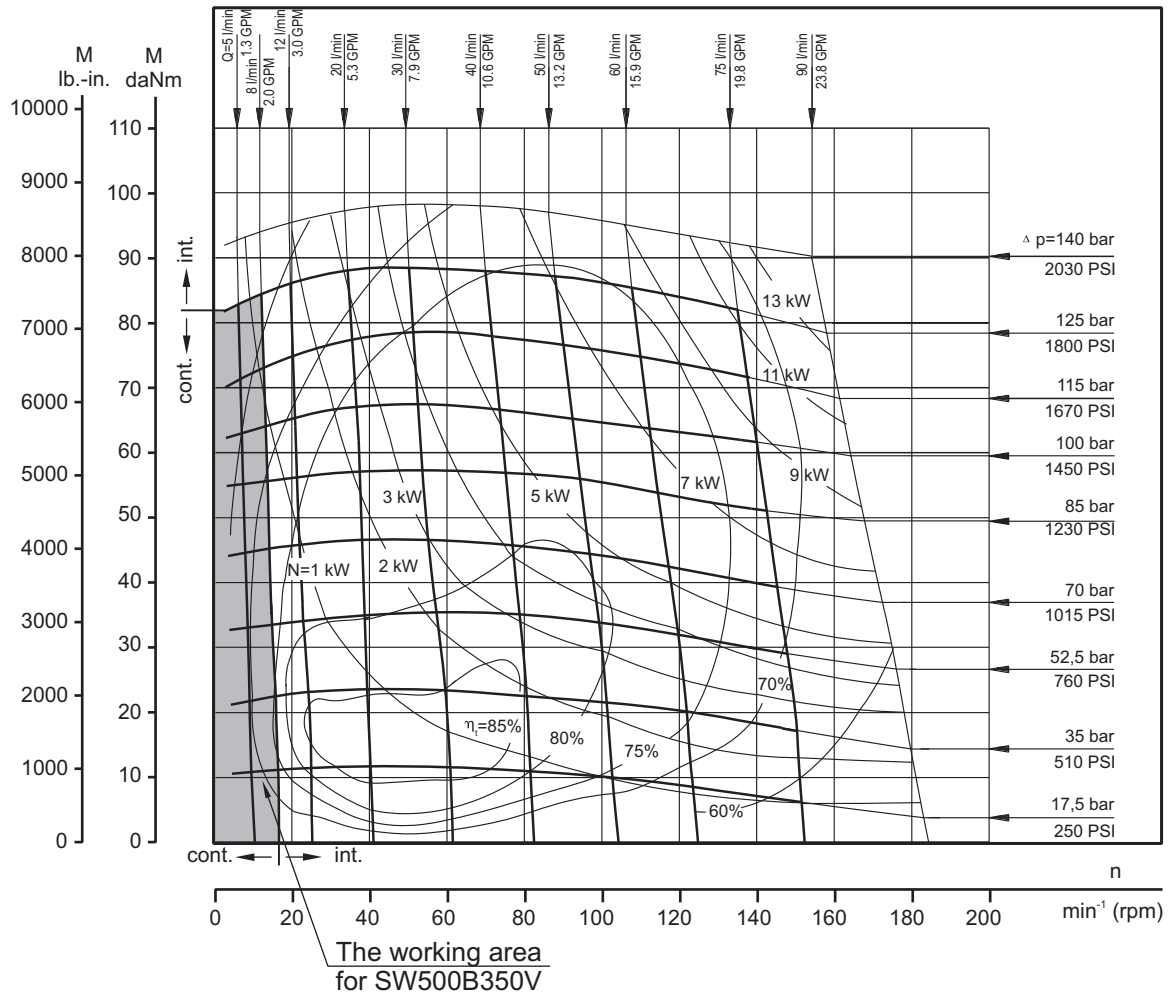

ORDER CODE

1	2	3	4	5	6	7	8
S	W	500	B	350	V		

- Pos.1 - Type
S - Motor MLHS
- Pos.2 - Displacement code
- Pos.3 - Brake
- Pos.4 - Brake Type

- Pos.5 - Shaft Extension
omit - 17T PITCH splined
- Pos.6 - Valve
- Pos.7 - Special Features (see page 64)
- Pos.8 - Design Series
omit - Factory specified

The motor-brakes are mangano-phosphatized as standard.

HYDRAULIC MOTOR-BRAKES TW500B350...V



APPLICATION

- » Wheel drives
- » Conveyors
- » Rotators
- » Positioners
- » Winches
- » Swing drives
- » Door openers

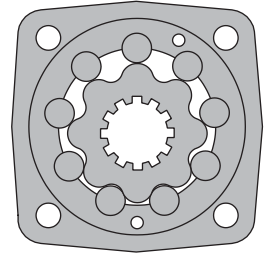

CONTENTS

Specification data	40
Dimensions and mounting	41
Function diagrams	41
Order code	42

Motor-Brake
Type TW500B350V

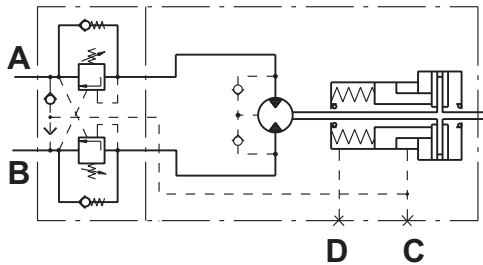

Motor-Brake
Type TW500B350CV

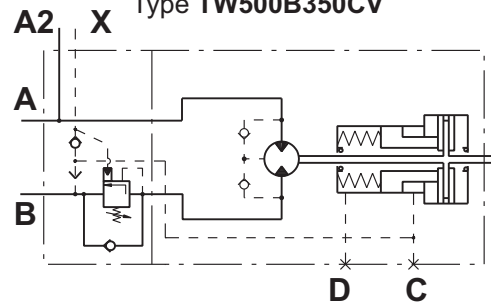

SPECIFICATION DATA

Type	TW500B350...V
Displacement, cm³/rev [in³/rev]	475 [29]
Max. Speed, RPM	40
Cont.	60
Int.*	
Max. Torque, daNm [lb-in]	114 [10 000]
Cont.	135 [12 000]
Int.*	
Max. Output, kW [HP]	4,1 [5.4]
Cont.	7,0 [9.39]
Int.*	
Max. Pressure Drop, bar [PSI]	170 [2500]
Cont.	200 [2900]
Int.*	
Max. Oil Flow, lpm [GPM]	20 [5.3]
Cont.	35 [9.2]
Int.*	
Max. Return Pressure without Drain Line or Max. Pressure in Drain Line, bar [PSI]	75 [1088]
Min. Starting Torque, daNm [lb-in]	95 [8400]
At max. press. drop Cont.	112 [9940]
At max. press. drop Int.*	
Min. Speed**, RPM	5
Static Torque for the Brake***, daNm [lb-in]	164 [14515]
Release Pressure ±10%, bar [PSI]	22,5...27,5 [326...400]
initial	28...34 [406...493]
full	
Max. Steering Pressure, bar [PSI]	245 [3553]
Max. Pressure in Drain Space for the Brake, bar [PSI]	0,5 [7]
Pilot Ratio for the Valve	4,25:1

* Intermittent operation: the permissible values may occur for max. 10% of every minute.

** For speeds of 5 RPM lower than given, consult factory or your regional manager.

*** Static torque is obtained at working pressure - 0 bar [0 PSI].

DIMENSIONS AND MOUNTING

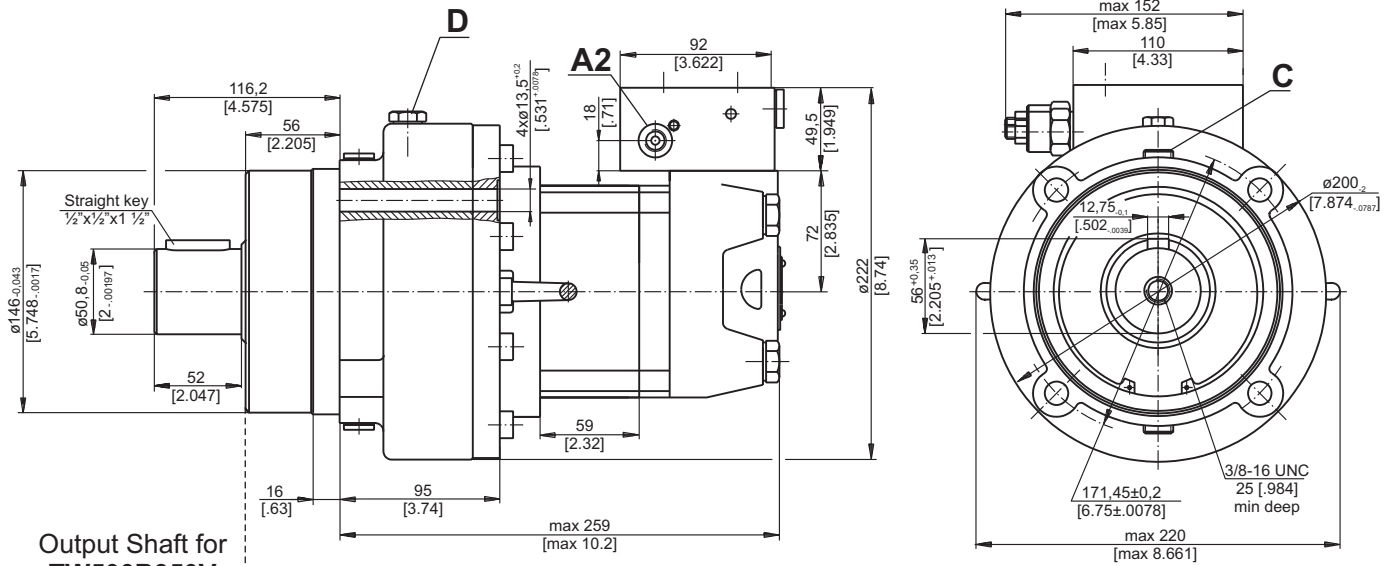

Output Shaft for TW500B350V

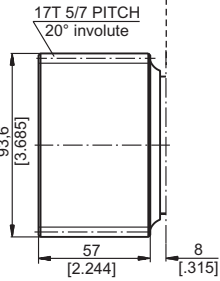

Valve Block for TW500B350V

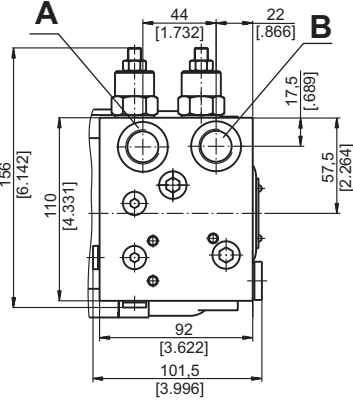

Valve Block for TW500B350CV

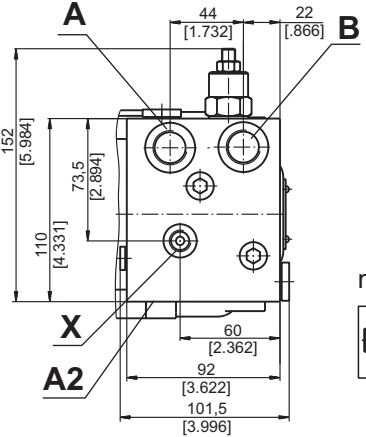

- A,B** : 2x7/8-14 UNF, 17,5 [.65] deep
- D** : 7/16-20 UNF
- C** : G1/4
- A2, X**: 7/16-18 UNF, 12 [.475] deep

Note: For different port's thread contact with "M+S Hydraulic".

PERMISSIBLE SHAFT LOADS

The curve applies to a B10 bearing life of 3000 hours at 40 RPM.

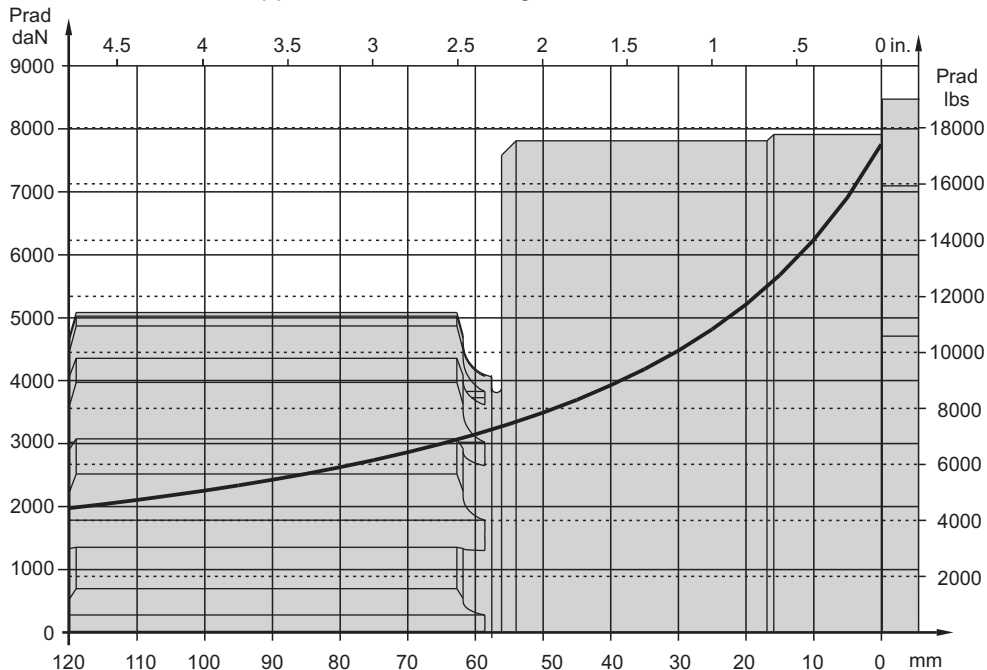

FUNCTION DIAGRAMS

TW 500

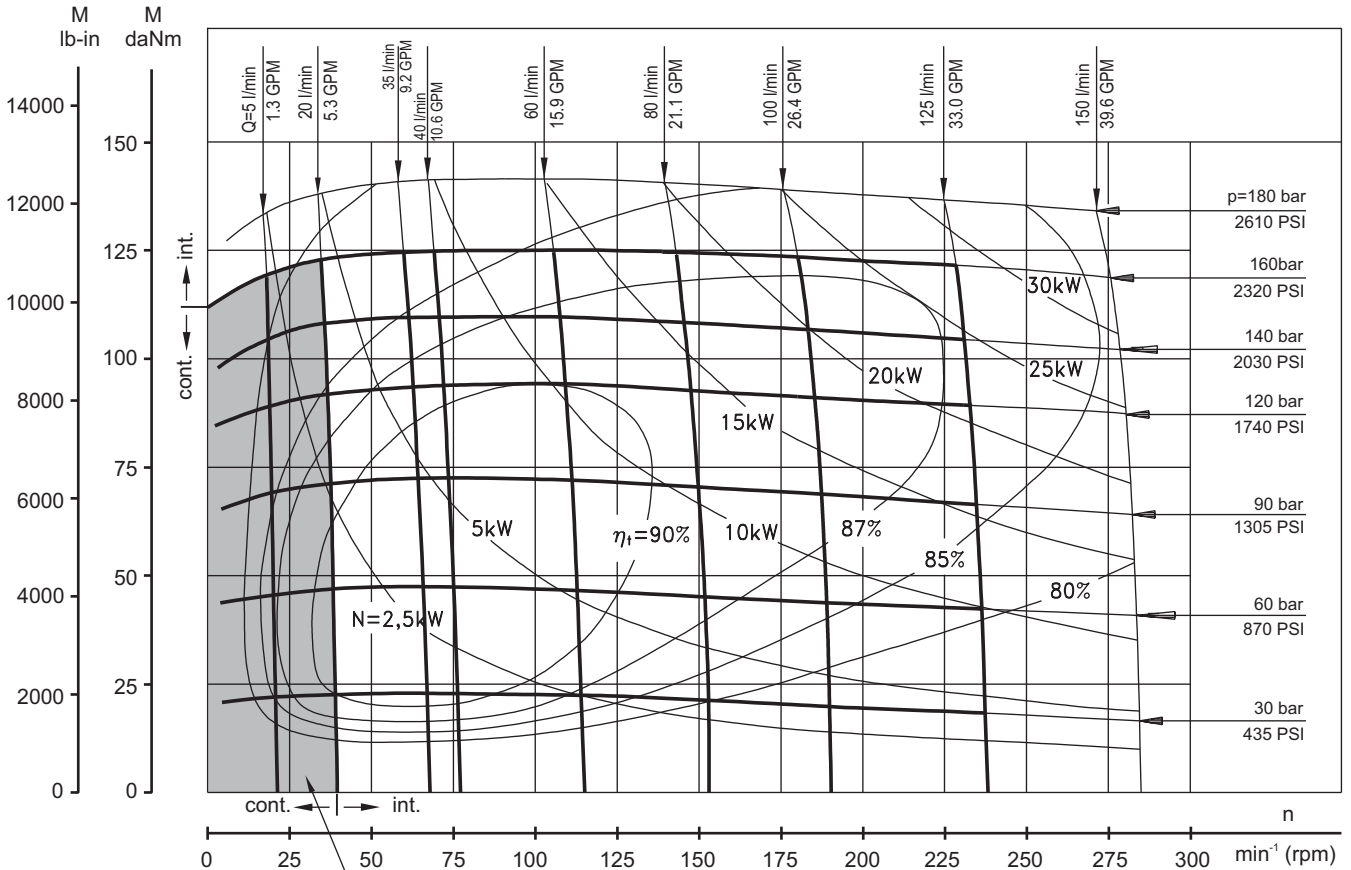

The working area
for TW500B350V

ORDER CODE

1	2	3	4	5	6	7	8
T	W	500	B	350	V		

Pos.1 - Type

T - Motor MLHT

Pos.2 - Displacement code

Pos.3 - Brake

Pos.4 - Brake Type

Pos.5 - Shaft Extension*

omit - 17T 5/7 pitch 20° involute

C - Straight key 1/2"x1/2"x1 1/2"

Pos.6 - Valve

Pos.7 - Special Features (see page 64)

Pos.8 - Design Series

omit - Factory specified

The motor-brakes are mangano-phosphatized as standard.

VALVES FOR HYDRAULIC MOTORS

CONTENTS

Valves for MP, MR and MH type KPBR ...	44	Crossover Relief Valves	53
Valves for MS type KPBS	45	Valves for MP, MR and MH type KP...R	54
Valves for MT type KPBT	46	Valves for MS type KP...S	54
Valves for MV type KPBV	47	Valves for MT type KP...T	55
Valves for RW and HW type KPBW	48	Valves for MV type KP...V	57
Valves for HP and HR type KPBHR...E ...	49	Valves for RW and HW type KP...W	59
Valves for HP and HR type KPBHR...D ...	50	Valves for HR and RK type KPDHR and KPDRK ...	61
Switch valves type KPWR and KPWS ...	51	Order Code	62+63
Switch valves type KPWT and KPWW	52		

OVERCENTER VALVES WITH BRAKE CONTROL

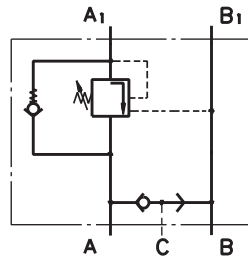

Single Overcenter Valves with Brake Control type KPBR ... AE

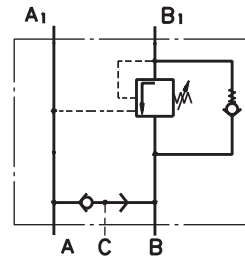

Single Overcenter Valves with Brake Control type KPBR ... BE

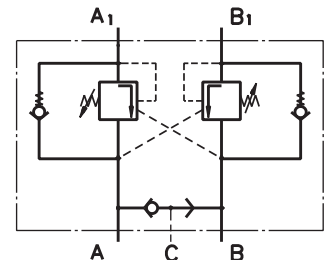

Dual Overcenter Valves with Brake Control type KPBR ... D

SPECIFICATION DATA

Parameters	Type											
	KPBR...E	KPBS...E	KPBR...D	KPBS...D	KPBW...E	KPBW...D	KPBHR...E	KPBHR...D	KPBT...E	KPBT...D	KPBV...E	KPBV...D
Flow Rate, lpm [GPM]	60 [15.85]						100 [26.4]		200 [52.8]			
Rated Pressure*, bar [PSI]	60÷280 [870÷4060]						70÷250 [1015÷3625]					
Pilot Ratio	4,25:1											
Weight, kg [lb]	3,020 [6.658]	2,900 [6.39]	3,060 [6.746]	2,920 [6.437]	3,050 [7.724]	3,140 [6.923]	2,300 [5.071]	2,400 [5.291]	5,400 [11.905]	5,800 [12.787]	9,200 [20.283]	9,750 [21.495]

*Pressure Settings are at flow rate of 5 lpm [1.3 GPM] and viscosity 32 mm²/s [150 SUS] at 50 °C [122 °F].

PRESSURE LOSSES

KPBR..., KPBS..., KPBW..., KPBHR...

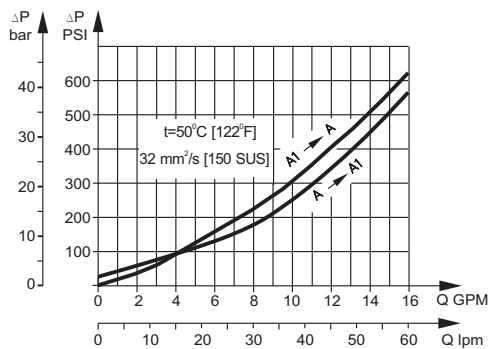

KPBT...

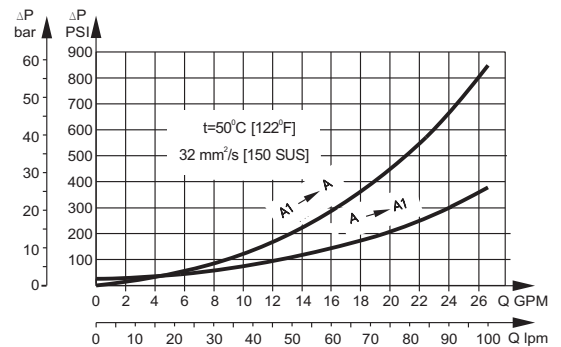

KPBV...

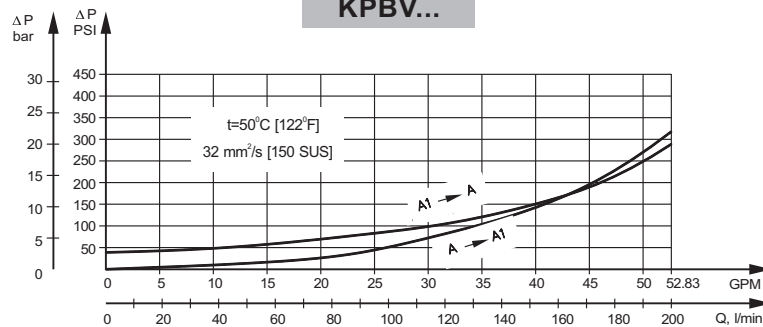

VALVES FOR MP, MR, MH HYDRAULIC MOTORS

SINGLE VALVE KPBR-250/1/E...

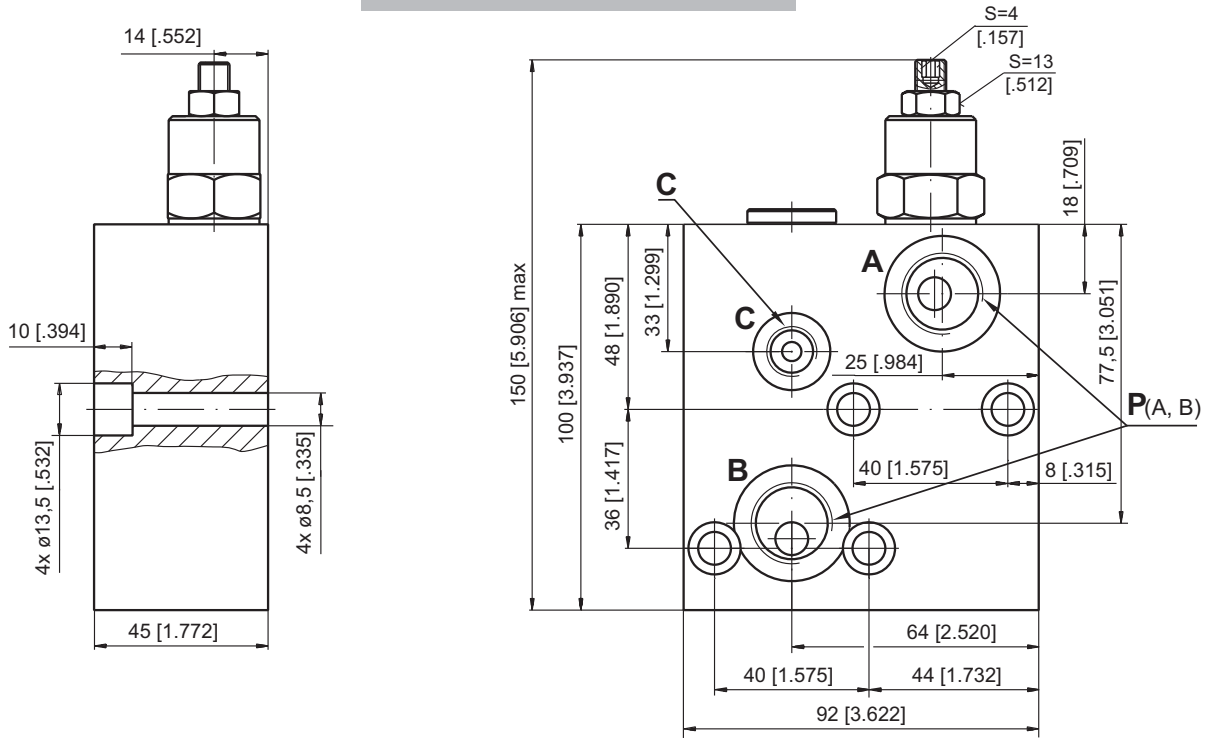

DUAL VALVE KPBR-250/1/D...

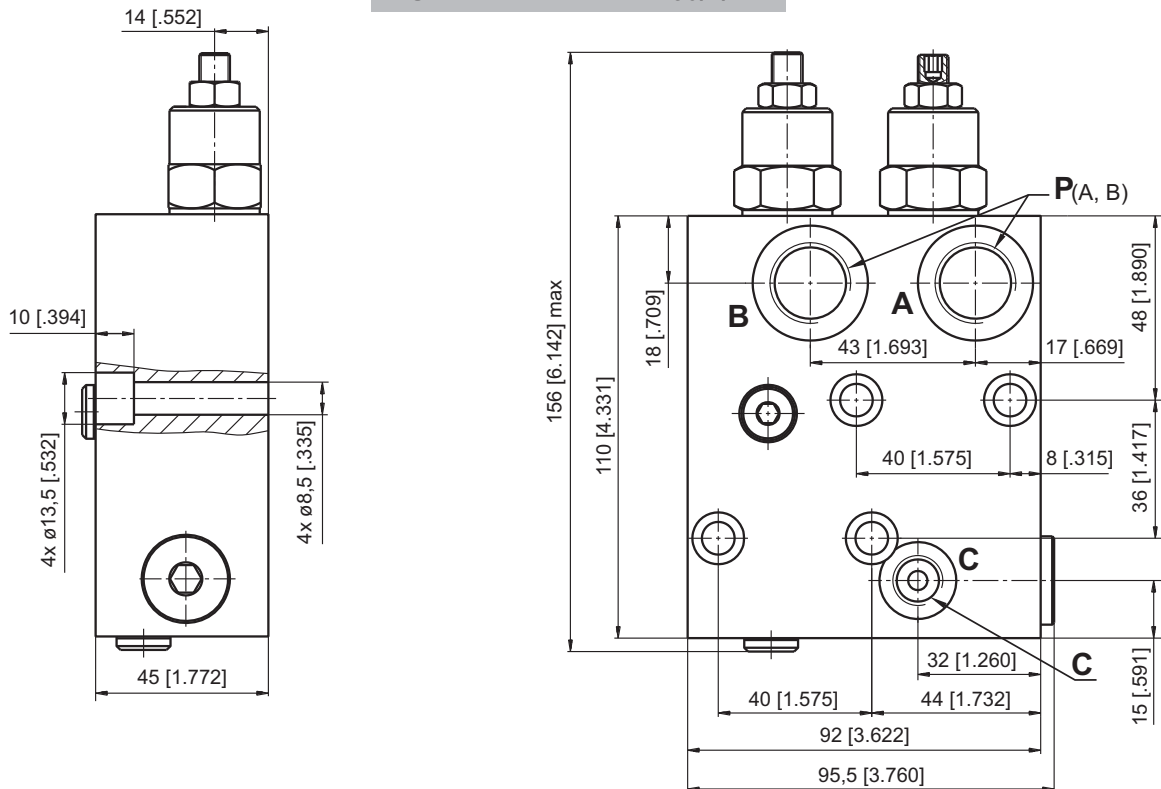

	Thread Ports - P _(A,B)	Thread Port - C
-	G1/2 16 [.63] depth	G1/4 12 [.47] depth
M	M22x1,5 16 [.63] depth	M14x1,5 12 [.47] depth
A	7/8 - 14 UNF O-ring 16 [.63] depth	7/16 - 20 UNF O-ring 12,7 [.50] depth



Note : KPBR Blocks are installed directly on MP, MR and MH Motors with four screws M8x45 - 8.8 DIN 912 or 5/16-18 UNC, 1.75 long ANSI B 18.3 . Tightening torque 2,0^{+0,5} daNm [177⁺⁴⁴ lb-in].

VALVES FOR MS HYDRAULIC MOTORS

SINGLE VALVE KPBS-250/1/E...

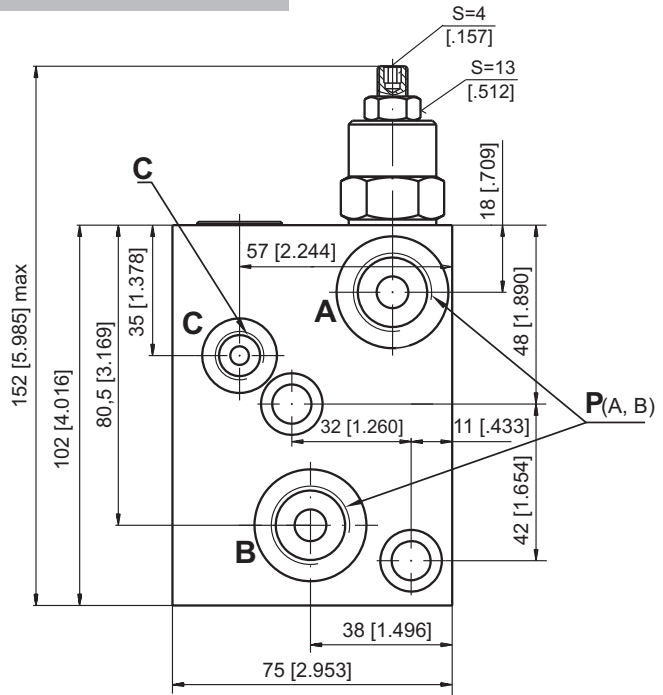
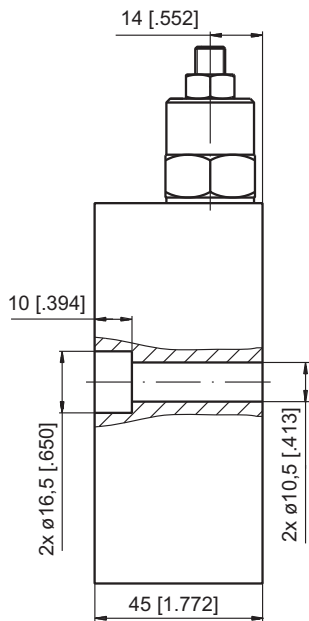

DUAL VALVE KPBS-250/1/D...

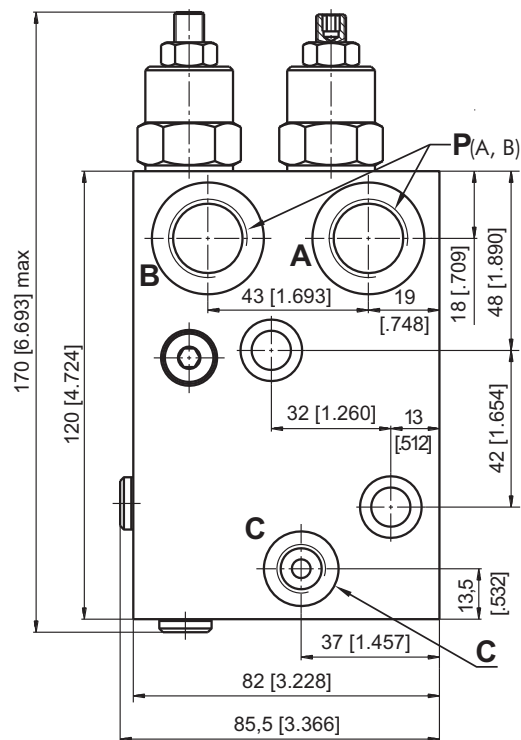
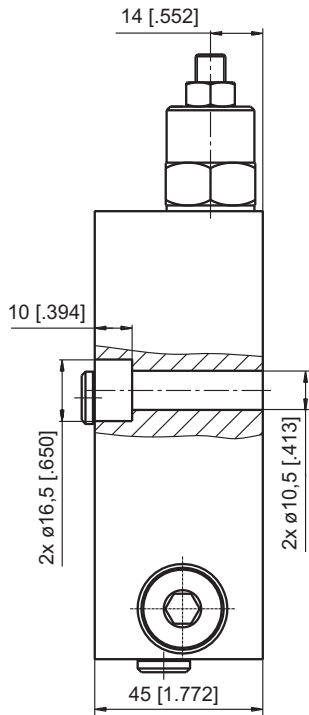

	Thread Ports - P _(A,B)	Thread Port - C
-	G1/2 16 [.63] depth	G1/4 12 [.47] depth
M	M22x1,5 16 [.63] depth	M14x1,5 12 [.47] depth
A	7/8 - 14 UNF O-ring 16 [.63] depth	7/16 - 20 UNF O-ring 12,7 [.50] depth



Note : KPBS Blocks are installed directly on MS Motors with two screws M10x45 - 8.8 DIN 912 or 3/8-16UNC, 1.75 long ANSI B 18.3 . Tightening torque 3,5 daNm [310 lb-in].

VALVES FOR MT HYDRAULIC MOTORS

SINGLE VALVE KPBT-250/1/AE...

SINGLE VALVE KPBT-250/1/BE...

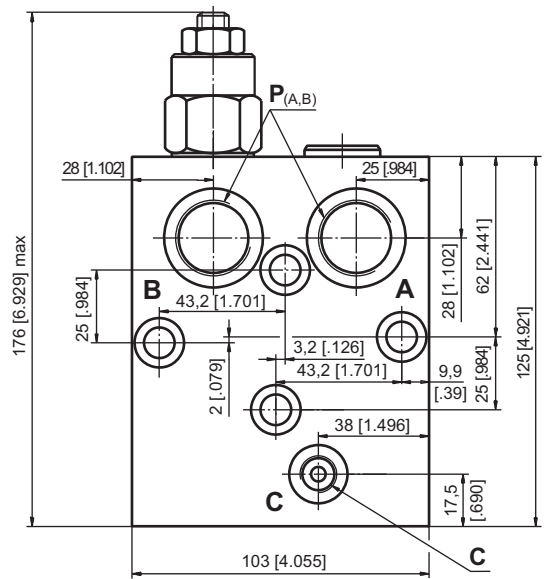
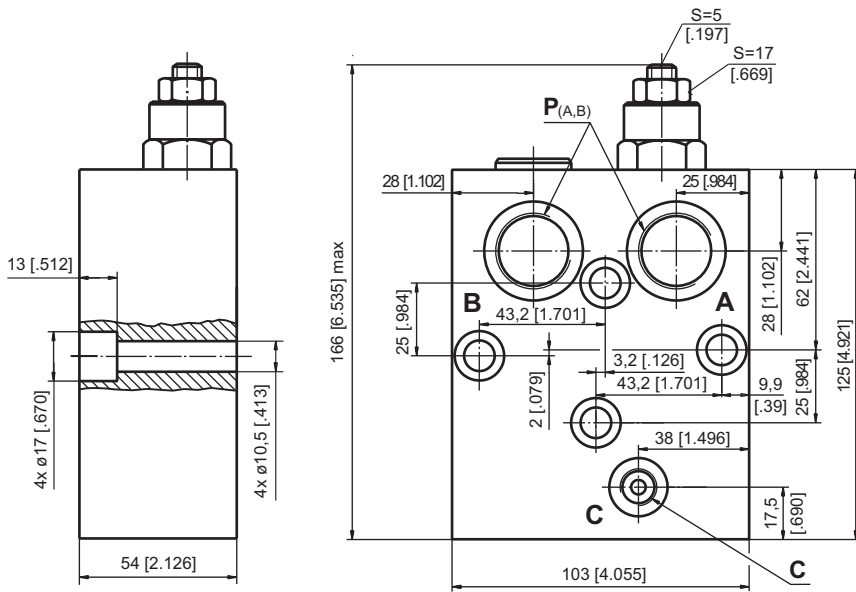

DUAL VALVE KPBT-250/1/D...

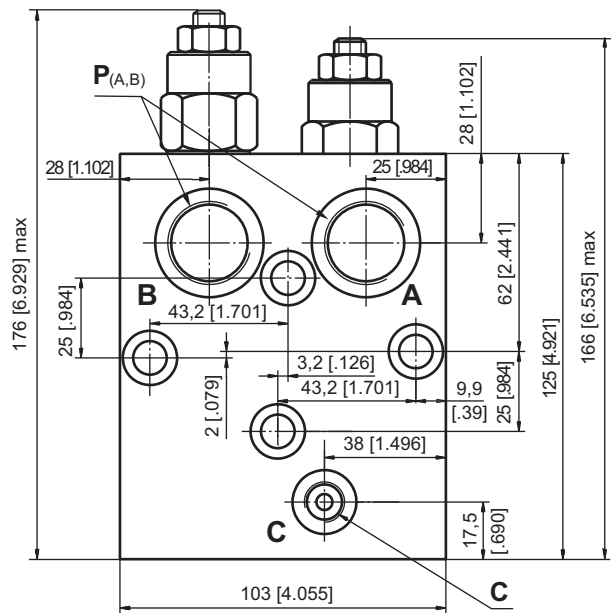
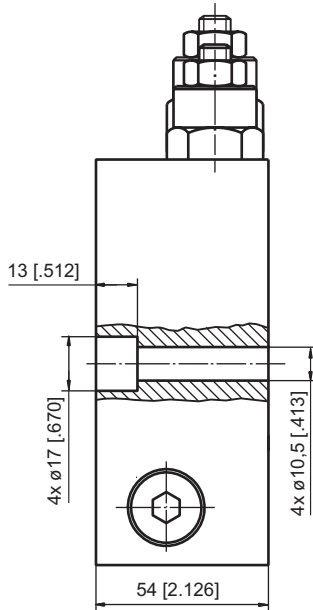

	Thread Ports - P _(A,B)	Thread Port - C
-	G3/4 17 [.67] depth	G1/4 14 [.55] depth
M	M27x2 17 [.67] depth	M14x1,5 14 [.55] depth
A	1 1/16-12 UN O-ring 17 [.67] depth	7/16 - 20 UNF O-ring 12,7 [.50] depth



Note : KPBT Blocks are installed directly on MT Motors with four screws M10x50 - 8.8 DIN 912. Tightening torque 3,5 daNm [310 lb-in].

VALVES FOR MV HYDRAULIC MOTORS

DUAL VALVE KPBV-250/1/D...

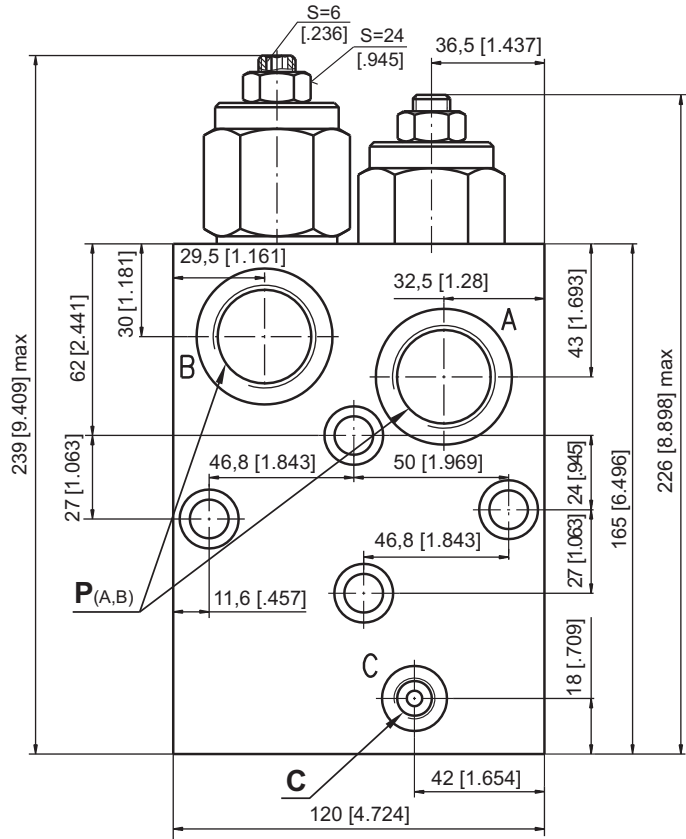
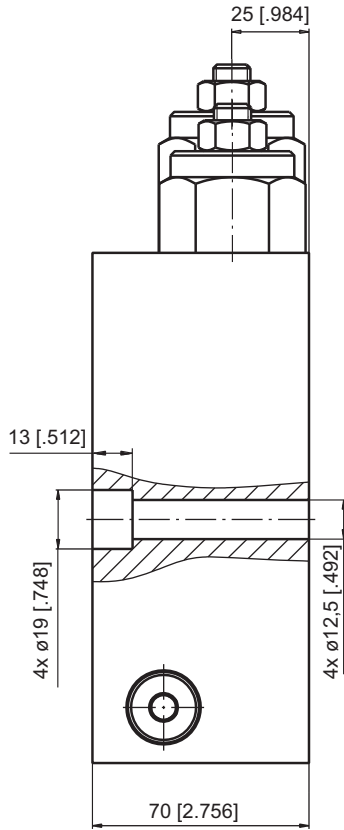

SINGLE VALVE KPBV-250/1/AE...

SINGLE VALVE KPBV-250/1/BE...

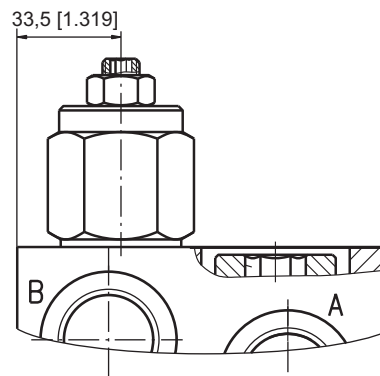
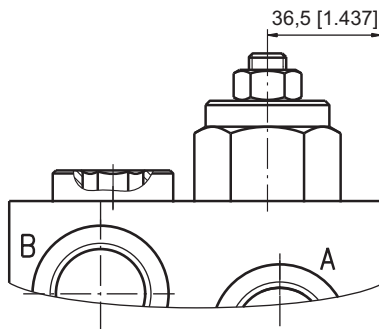

	Thread Ports - P _(A,B)	Thread Port - C
-	G 1 20 [.79] depth	G1/4 14 [.55] depth
M	M33x2 20 [.79] depth	M14x1,5 14 [.55] depth
A	1 5/16 - 12 UN O-ring 20 [.79] depth	7/16 - 20 UNF O-ring 12,7 [.50] depth



Note : KPBV Blocks are installed directly on MV Motors with four screws M12x70 - 8.8 DIN 912. Tightening torque 6,5 daNm [575 lb-in].

VALVES FOR RW and HW HYDRAULIC MOTORS

DUAL VALVE KPBW-250/1/D...

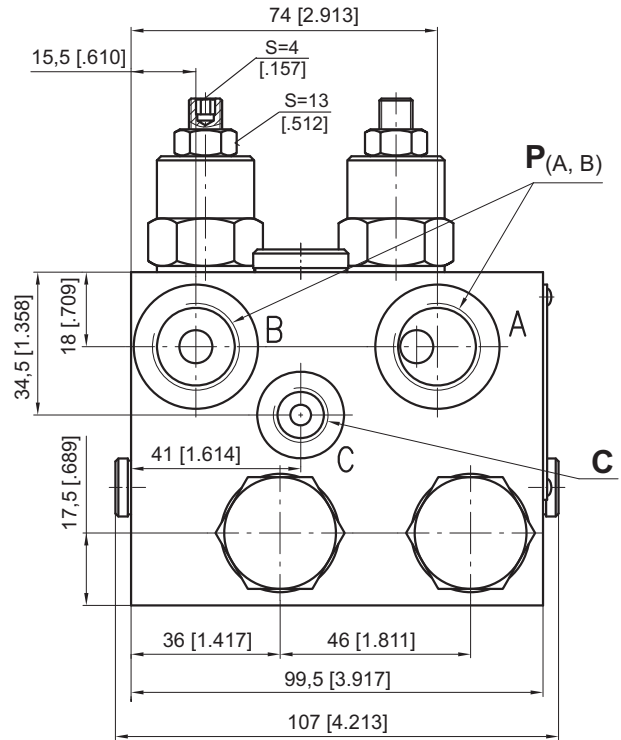
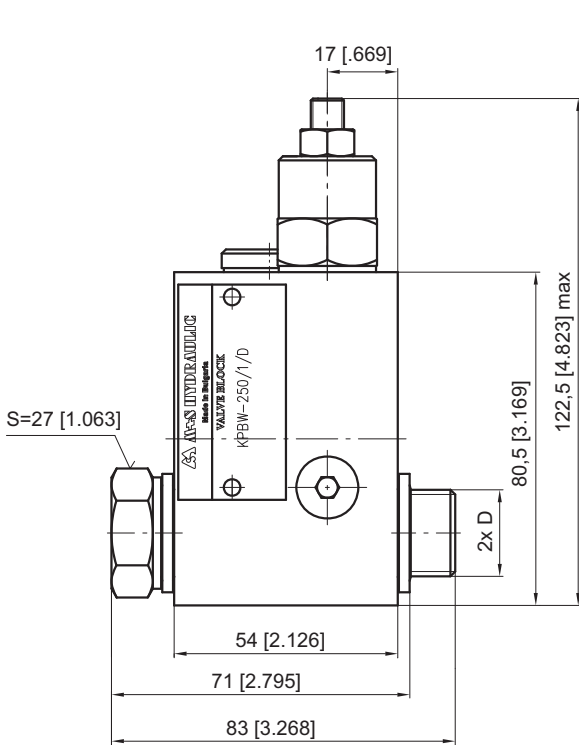

KPBW-...A

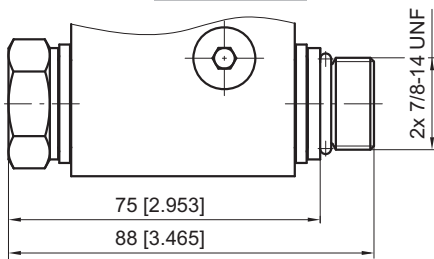

SINGLE VALVE KPBW-250/1/AE...

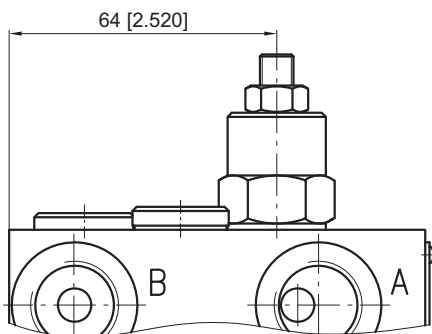

SINGLE VALVE KPBW-250/1/BE...

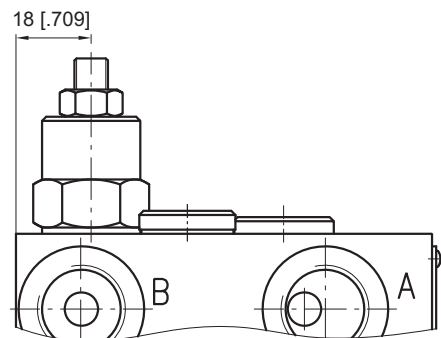

	Thread Ports - P _(A,B)	Thread Port - C	Thread Ports - D
-	G1/2 16 [0.63] depth	G1/4 12 [0.47] depth	G1/2 12 [0.47] length
M	M22x1,5 16 [0.63] depth	M14x1,5 12 [0.47] depth	M22x1,5 12 [0.47] length
A	7/8 - 14 UNF O-ring 16 [0.63] depth	7/16 - 20 UNF O-ring 12,7 [0.50] depth	7/8 - 14 UNF O-ring 13 [0.51] length



Note : KPBW Blocks assembly to RW or HW motors is done with two screws (thread D) included in the valve set. Tightening torque 8 daNm [710 lb-in].



SPECIFICATION DATA

Parameters	Type	
	KPWR	KPWS
Flow Rate , l/min [GPM]	60	[15.85]
Rated Pressure , bar [PSI]	250	[3625]
Weight , kg	0,850	0,670
[lb]	[1.874]	[1.477]

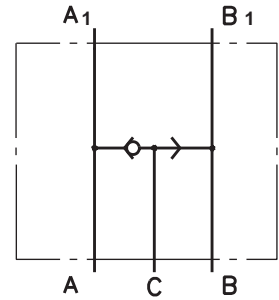

**VALVE FOR MP, MR, MH HYDRAULIC MOTORS
KPWR**

**VALVE FOR MS HYDRAULIC MOTORS
KPWS**

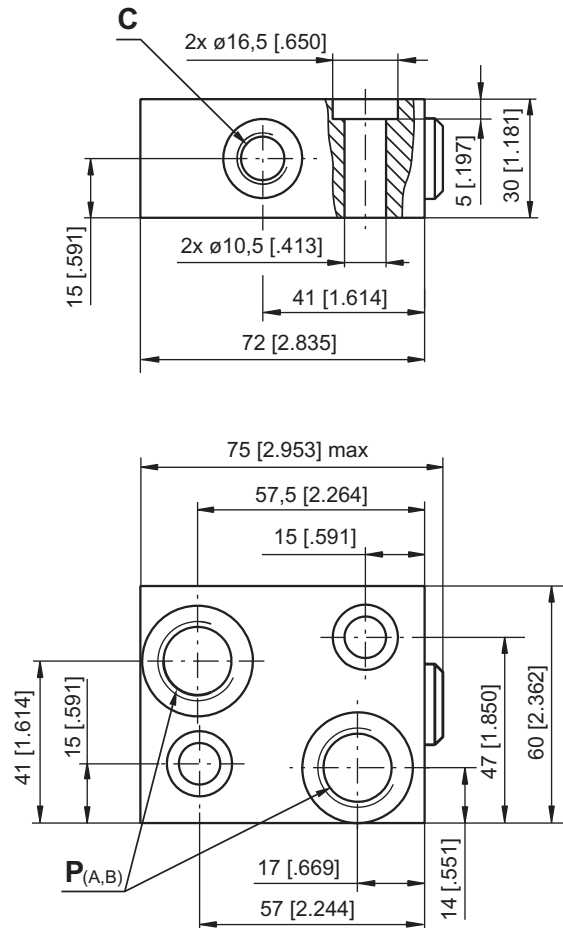
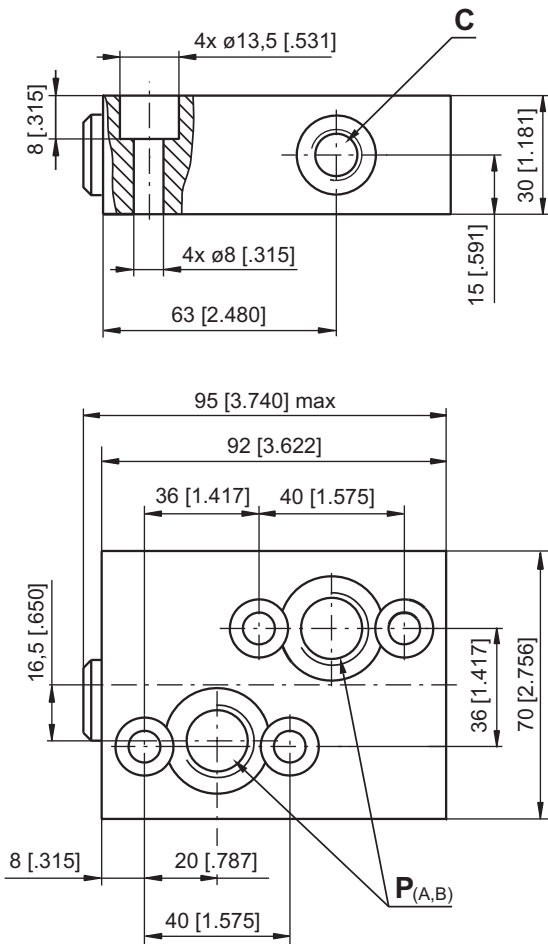

	Thread Ports - $P_{(A,B)}$	Thread Port - C
-	G1/2 17 [.67] depth	G1/4 14 [.55] depth
M	M22x1,5 17 [.67] depth	M14x1,5 14 [.55] depth
A	7/8 - 14 UNF O-ring 17 [.67] depth	7/16 - 20 UNF O-ring 12,7 [.50] depth



Note : **KPWR** Blocks are installed directly on MP, MR and MH Motors with four screws M8x35 - 8.8 DIN 912 or 5/16-18UNC, 1.5 long ANSI B 18.3 . Tightening torque $2,0^{+0,5}$ daNm [177⁺⁴⁴ lb-in].

KPWS Blocks are installed directly on MS Motors with two screws M10x35 - 8.8 DIN 912 or 3/8-16UNC, 1.5 long ANSI B 18.3 . Tightening torque 3,5 daNm [336 lb-in].

SWITCH VALVE (continued)

SPECIFICATION DATA

Parameters	Type	
	KPWT	KPWW
Flow Rate , l/min [GPM]	100 [26.4]	200 [52.8]
Rated Pressure , bar [PSI]	250	[3625]
Weight , kg [lb]	1,800 [3.968]	3,150 [6.945]

**VALVE FOR MT HYDRAULIC MOTORS
KPWT**

**VALVE FOR MV HYDRAULIC MOTORS
KPWW**

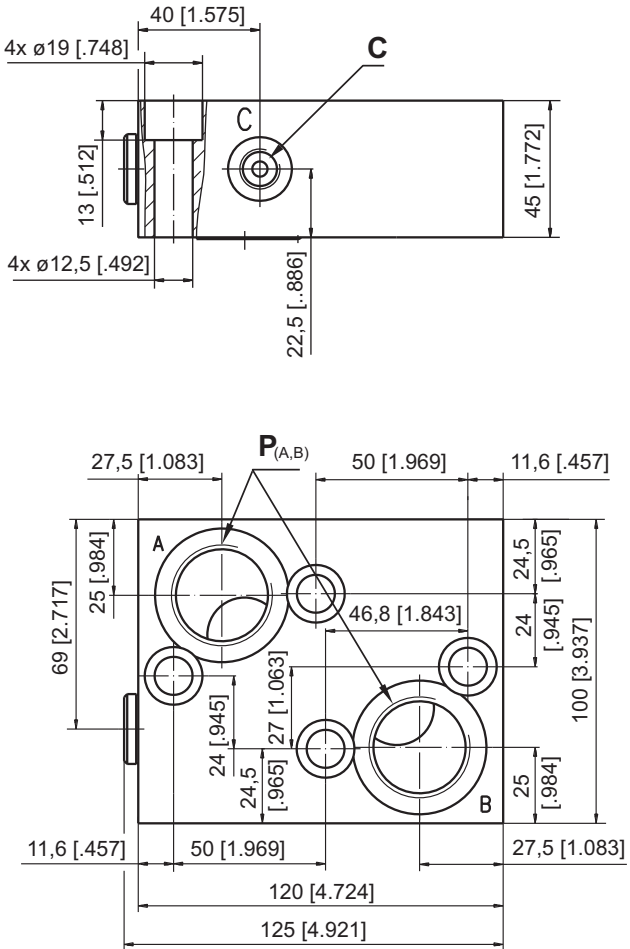
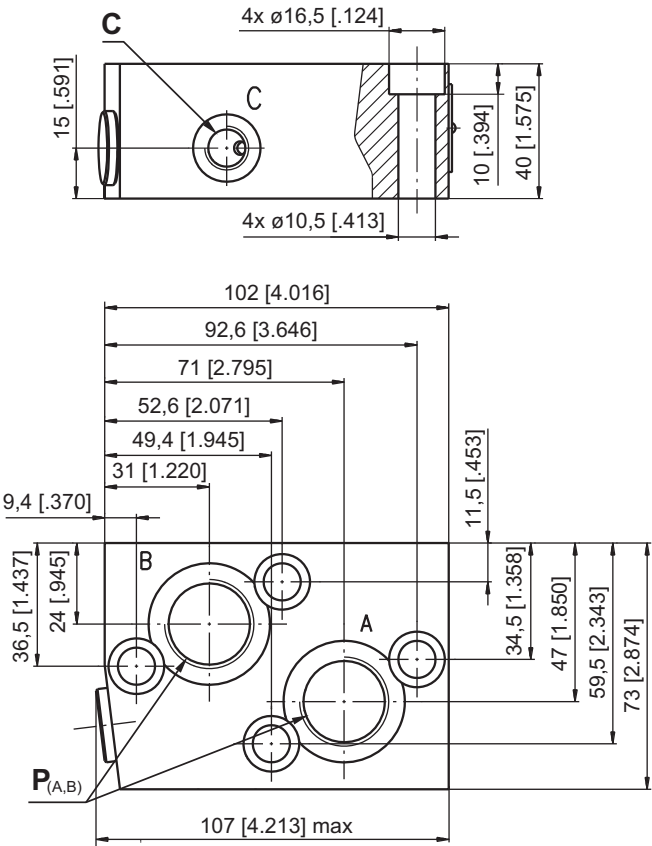

	Thread Ports - P _(A,B)	Thread Port - C
-	G3/4 17 [.67] depth	G1/4 14 [.55] depth
M	M27x2 17 [.67] depth	M14x1,5 14 [.55] depth
A	1 1/16-12 UN O-ring 17 [.67] depth	7/16 - 20 UNF O-ring 12,7 [.50] depth



	Thread Ports - P _(A,B)	Thread Port - C
-	G 1 20 [.79] depth	G1/4 14 [.55] depth
M	M33x2 20 [.79] depth	M14x1,5 14 [.55] depth
A	1 5/16 - 12 UN O-ring 20 [.79] depth	7/16 - 20 UNF O-ring 12,7 [.50] depth

Note : KPWT Blocks are installed directly on MT Motors with four screws M10x40 - 8.8 DIN 912. Tightening torque 3,5 daNm [336 lb-in].
 KPWW Blocks are installed directly on MV Motors with four screws M12x45 - 8.8 DIN 912. Tightening torque 6,5 daNm [425 lb-in].

CROSSOVER RELIEF VALVES

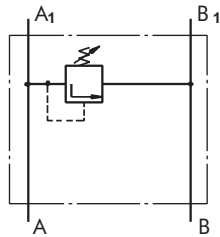

Single Crossover Relief Valve type KPE ...

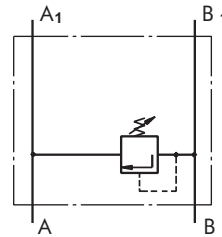

Single Crossover Relief Valve type KPE ...

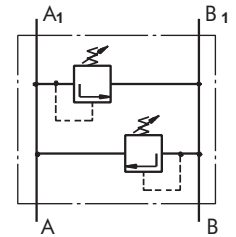

Dual Crossover Relief Valve type KPD ...

SPECIFICATION DATA

Parameters	Type			
	KPER	KPDR	KPES	KPDS
Flow Rate , lpm [GPM]	60 [15.85]			
Pressure Range* , bar [PSI]	30 ÷ 100; [435÷1450]	50 ÷ 210; [725÷3050]	80 ÷ 300 [1160÷4350]	
Weight , kg [lb]	1,55 [3.42]		1,50 [3.31]	

*Pressure Settings are at flow rate of 5 lpm [1.32 GPM] and viscosity 32 mm²/s [150 SUS] (50 °C [122° F]).

Rated Pressure

- A → 100 bar [1450 PSI]
- B → 210 bar [3050 PSI]
- C → 250 bar [3625 PSI]

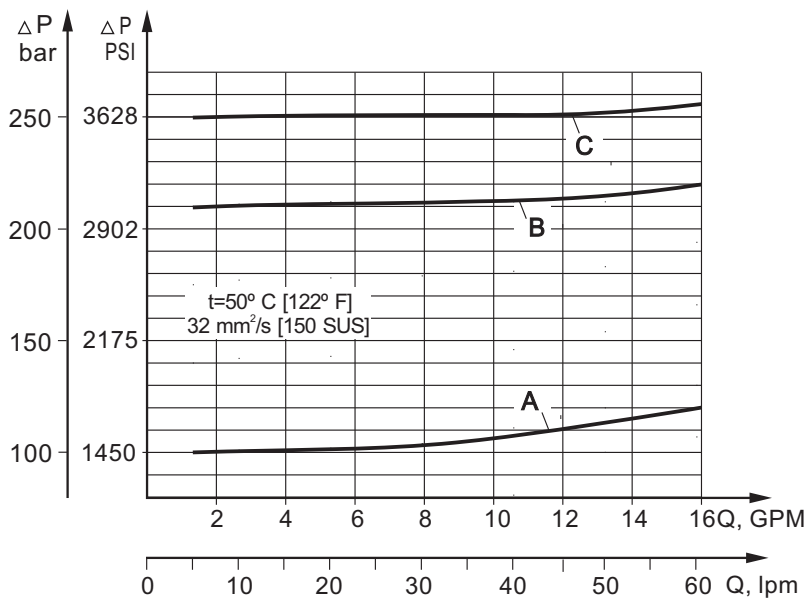

**VALVES FOR MP, MR, MH
HYDRAULIC MOTORS**

**VALVES FOR MS
HYDRAULIC MOTORS**

DUAL VALVE KPDR

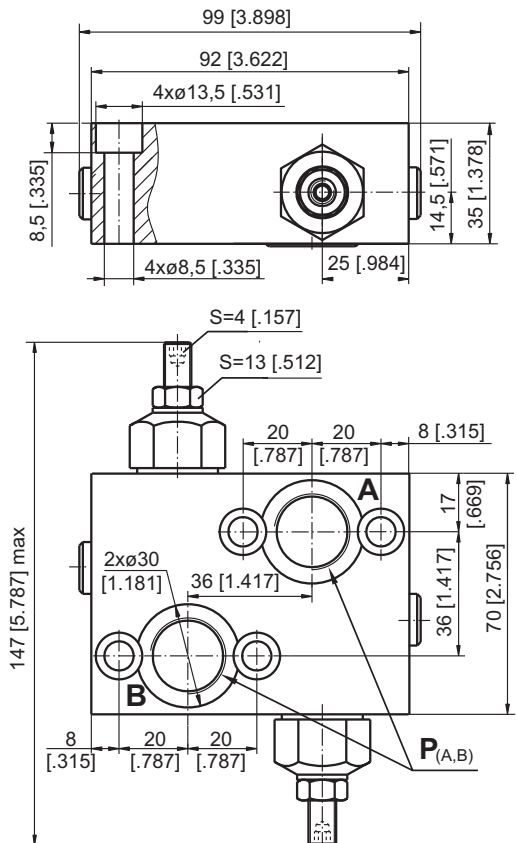

DUAL VALVE KPDS

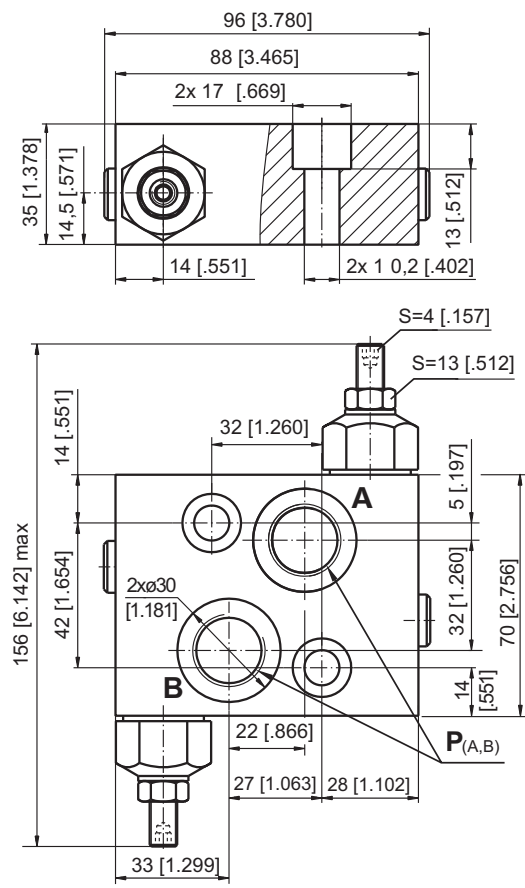

SINGLE VALVE KPER

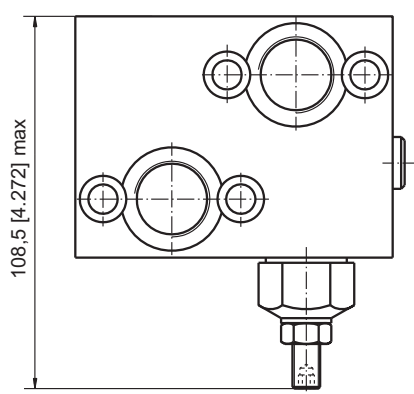

SINGLE VALVE KPES

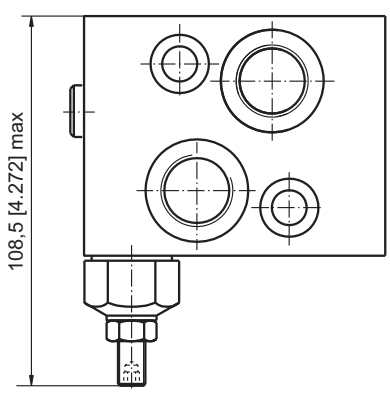

	Thread Ports - P _(A,B)
-	G1/2 20 [.79] depth
M	M22x1,5 20 [.79] depth
A	7/8 - 14 UNF O-ring 20 [.79] depth

Note : **KPDR** and **KPER** Blocks are installed directly on MP, MR and MH Motors with four screws M8x35 - 8.8 DIN 912 or 5/16-18 UNC, 1.5 long ANSI B 18.3 . Tightening torque 2,0^{+0,5} daNm [177⁺⁴⁴ lb-in].

KPDS and **KPES** Blocks are installed directly on MS Motors with two screws M10x35 - 8.8 DIN 912 or 3/8-16 UNC, 1.5 long ANSI B 18.3 . Tightening torque 3,5 daNm [310 lb-in].

VALVES FOR MT HYDRAULIC MOTORS

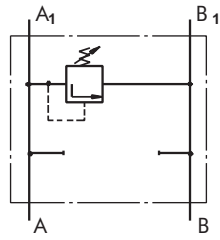

Single Crossover
Relief Valve
type KPEAT ...

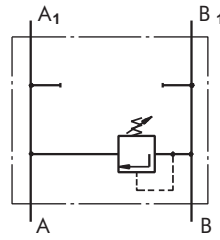

Single Crossover
Relief Valve
type KPEBT ...

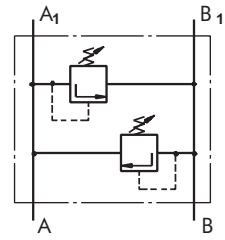

Dual Crossover
Relief Valve
type KPDT ...

SPECIFICATION DATA

Parameters	Type	
	KPE...T	KPDT
Flow Rate , lpm [GPM]	120 [32]	
Pressure Range* , bar [PSI]	80÷210 [1160÷3050]	
Weight , kg [lb]	5,10 [11.24]	5,54 [12.21]

*Pressure Settings are at flow rate of 5 lpm [1.32 GPM] and viscosity 32 mm²/s [150 SUS] (50 °C [122° F]).

Rated Pressure

- A → 50 bar [725 PSI]
- B → 100 bar [1450 PSI]
- C → 150 bar [2175 PSI]
- D → 210 bar [3045 PSI]

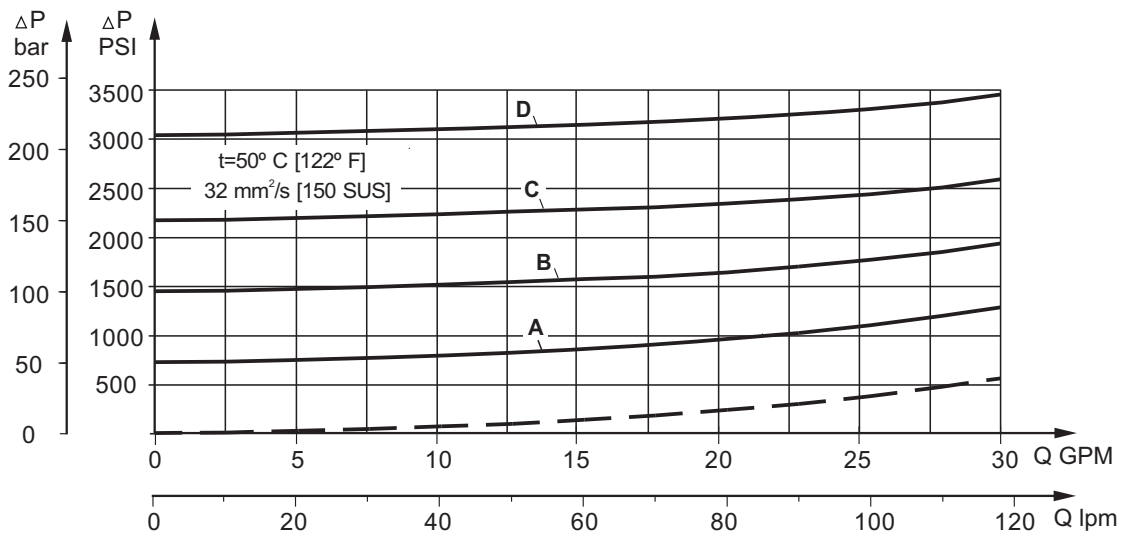

DUAL VALVE KPDT...

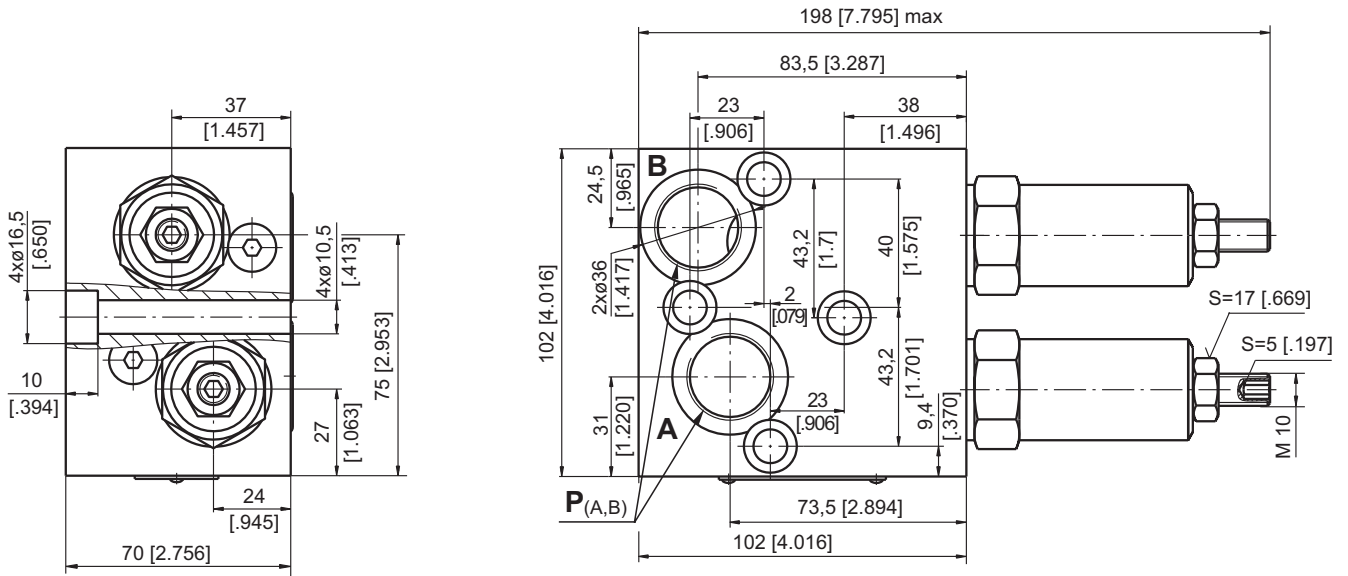

SINGLE VALVE KPEAT...

SINGLE VALVE KPEBT...

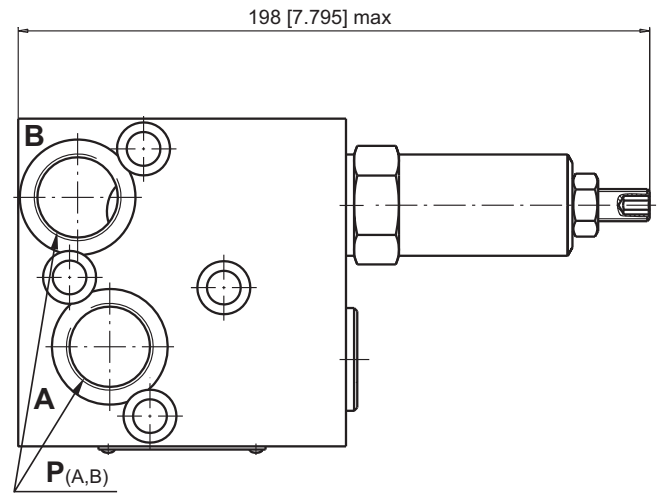
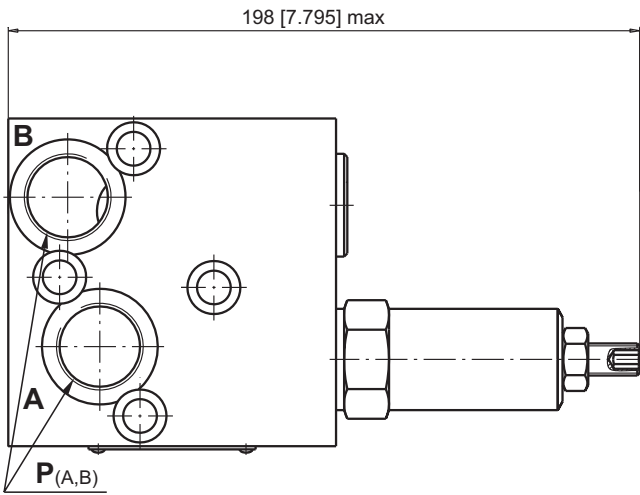

Thread Ports - P _(A,B)	
-	G3/4 20 [.79] depth
M	M27x2 20 [.79] depth
A	1 ¹ / ₁₆ -12 UN O-ring 20 [.79] depth

Note : KPDT and KPE...T Blocks are installed directly on MT Motors with four screws M10x70 - 8.8 DIN 912. Tightening torque 3,5 daNm [310 lb-in].

VALVES FOR MV HYDRAULIC MOTORS

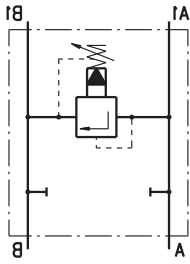

Single Crossover Relief Valve type KPEAV ...

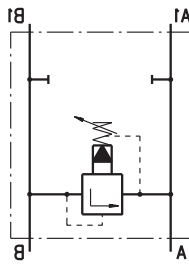

Single Crossover Relief Valve type KPEBV ...

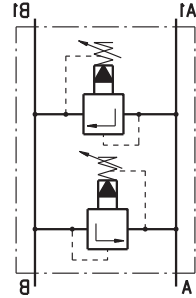

Dual Crossover Relief Valve type KPDRV ...

SPECIFICATION DATA

Parameters	Type		
	KPEAV	KPEBV	KPDRV
Flow Rate , lpm [GPM]	200 [53]		
Pressure Range* , bar [PSI]	10÷100; 20÷250 [145÷1450]; [290÷3625]		
Weight , kg [lb]	4,90 [10.8]	7,10 [15.65]	8,00 [17.64]

*Pressure Settings are at flow rate of 5 lpm [1.3 GPM] and viscosity 32 mm²/s [150 SUS] (50 °C [122° F]).

Rated Pressure

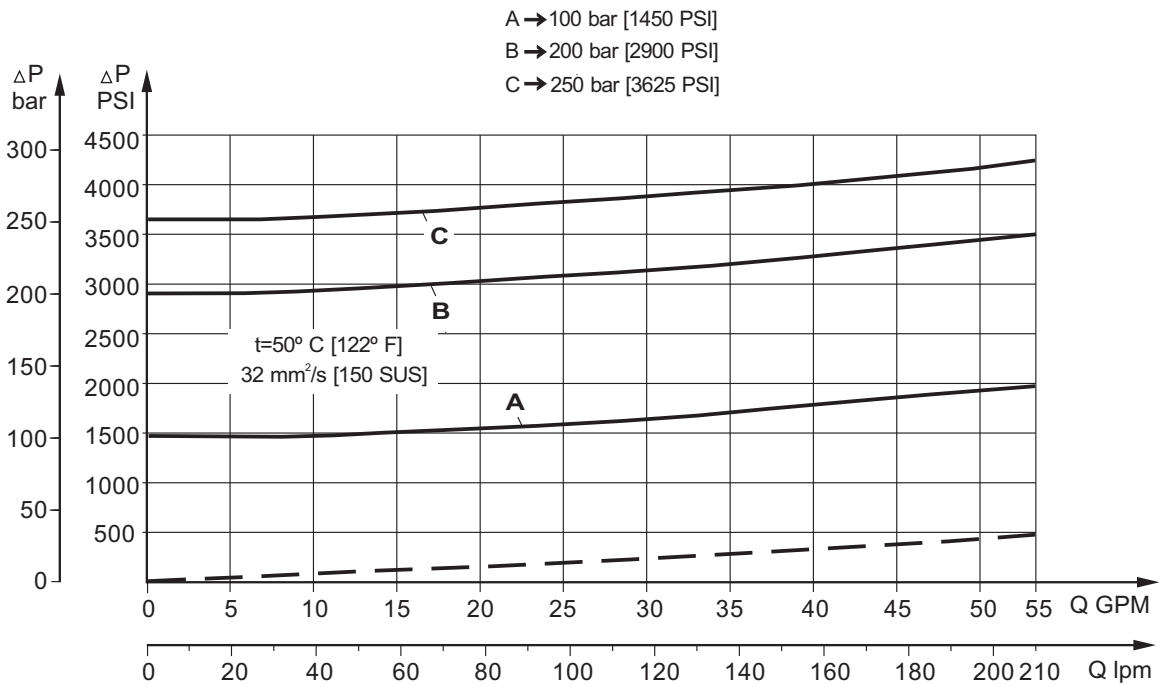

DUAL VALVE KPDV

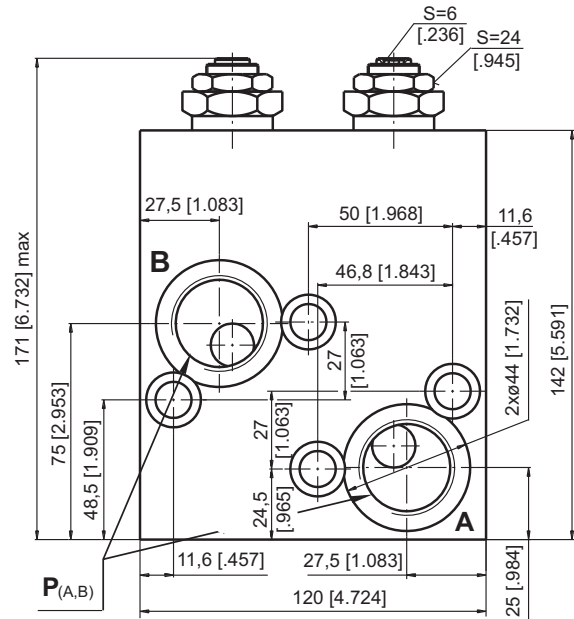
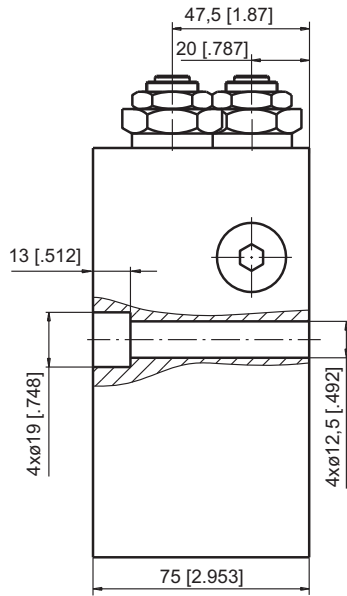

SINGLE VALVE KPEAV

SINGLE VALVE KPEBV

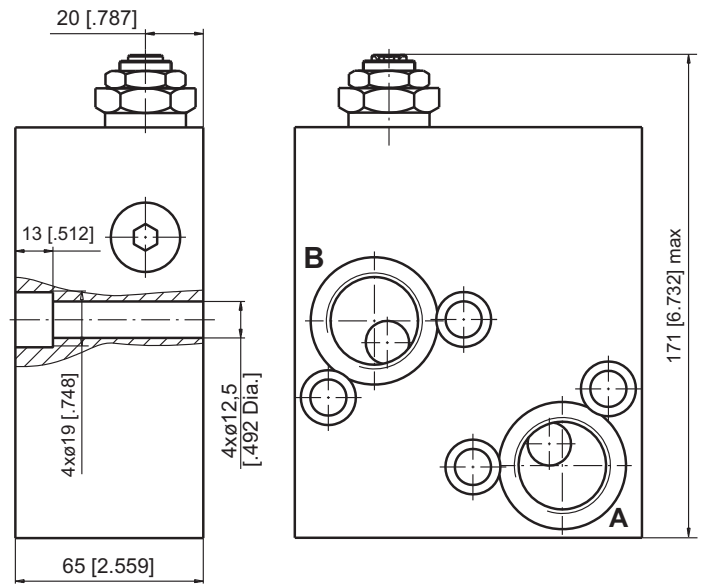
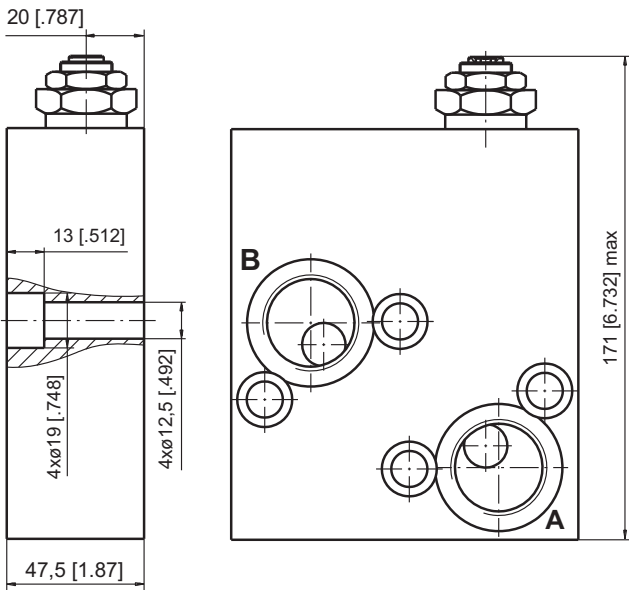

	Thread Ports - P _(A,B)
-	G1-A 20 [.79] depth
M	M33x2 20 [.79] depth
A	1 ⁵ / ₁₆ -12 UN O-ring 20 [.79] depth

Note : KPDV Blocks are installed directly on MV Motors with four screws M12x75 - 8.8 DIN 912.
 KPEAV Blocks are installed directly on MV Motors with four screws M12x50 - 8.8 DIN 912.
 KPEBV Blocks are installed directly on MV Motors with four screws M12x65 - 8.8 DIN 912.
 Tightening torque 7,5 daNm [665 lb-in].

VALVES FOR RW and HW HYDRAULIC MOTORS

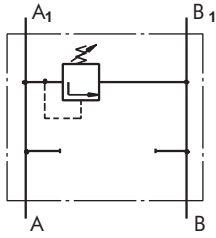

Single Crossover Relief Valve type KPEAW ...

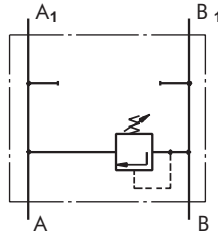

Single Crossover Relief Valve type KPEBW ...

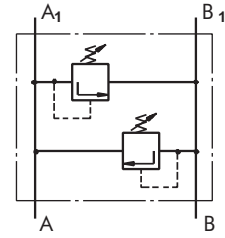

Dual Crossover Relief Valve type KPDW ...

SPECIFICATION DATA

Parameters	Type	
	KPE...W	KPDW
Flow Rate , lpm [GPM]	60 [15.85]	
Pressure Range* , bar [PSI]	5 ÷ 40; 30 ÷ 100; 80 ÷ 250 [75÷580]; [435÷1450]; [1160÷3625]	
Weight , kg [lb]	2,700 [5.95]	2,800 [6.17]

*Pressure Settings are at flow rate of 5 lpm [1.32 GPM] and viscosity 32 mm²/s [150 SUS] (50 °C [122° F]).

Rated Pressure

- A → 100 bar [1450 PSI]
- B → 210 bar [3050 PSI]
- C → 250 bar [3625 PSI]

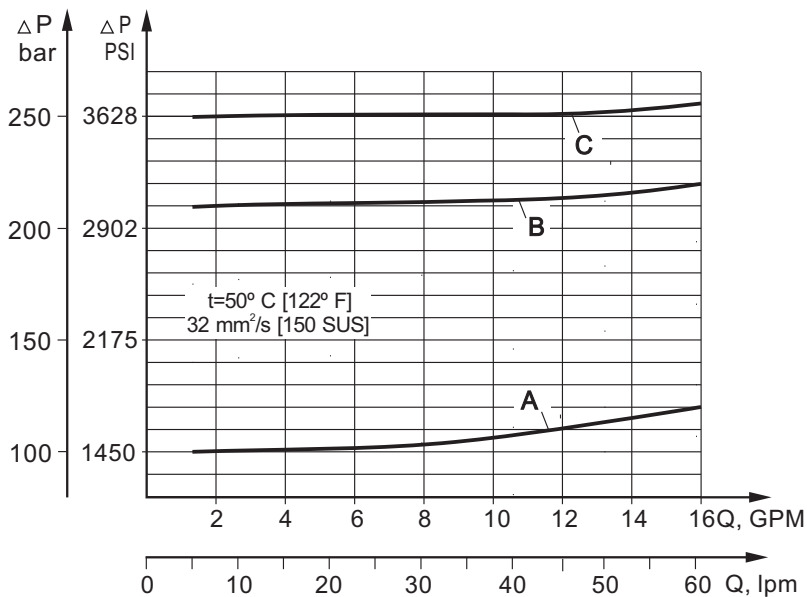

VALVES FOR RW and HW HYDRAULIC MOTORS

DUAL VALVE KPDW...

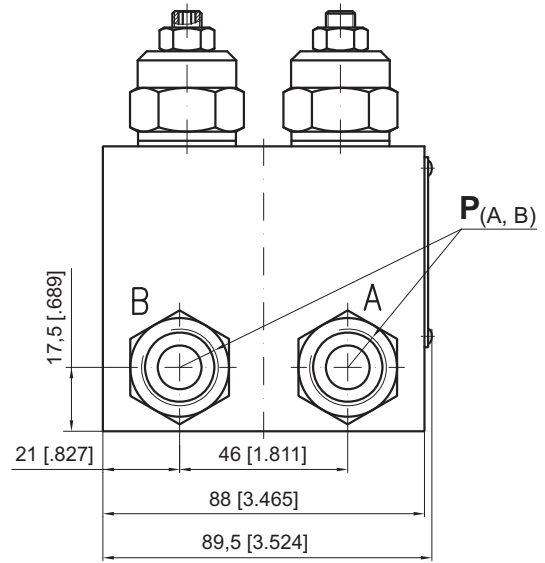
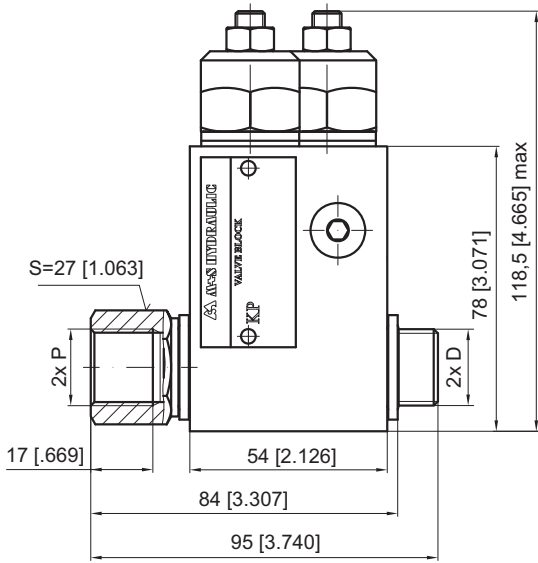

KPDW-...A

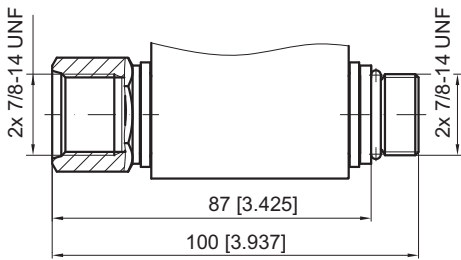

SINGLE VALVE KPEAW...

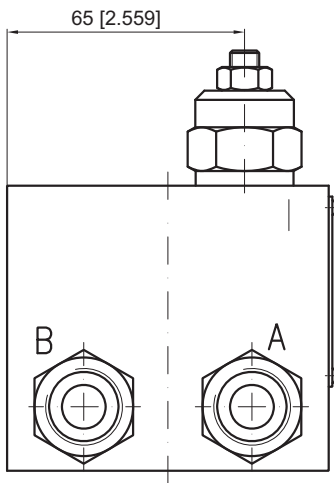

SINGLE VALVE KPEBW...

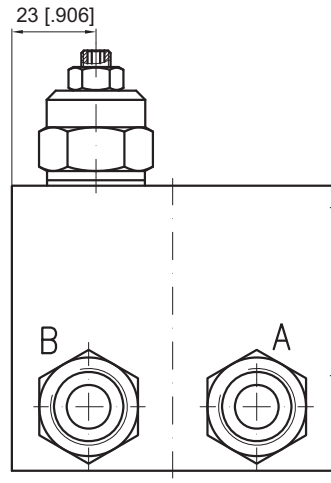

mm [in]

	Thread Ports - P _(A,B)	Thread Ports - D
-	G1/2 16 [.63] depth	G1/2 12 [.47] length
M	M22x1,5 16 [.63] depth	M22x1,5 12 [.47] length
A	7/8 - 14 UNF O-ring 16 [.63] depth	7/8 - 14 UNF O-ring 13 [.51] length

Note : KPDW and KPE..W Blocks assembly to RW or HW motors is done with two screws (thread D) included in the valve set. Tightening torque 8 daNm [710 lb-in].

CROSSOVER RELIEF VALVES

SPECIFICATION DATA

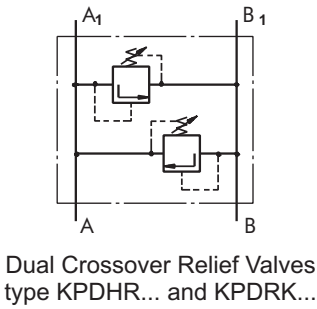

Parameters	Type					
	KPDHR			KPDRK		
Flow Rate, lpm [GPM]	60 [15.85]					
Pressure bar	5÷40	30÷100	80÷250	10÷40	30÷100	80÷250
Range*, [PSI]	[70÷580]	[435÷1450]	[1160÷3625]	[145÷580]	[435÷1450]	[1160÷3625]
Weight, kg [lb]	2,420 [5.34]			1,600 [3.53]		

*Pressure Settings are at flow rate of 5 lpm [1.3 GPM] and viscosity 32 mm²/s [150 SUS] (50 °C [122° F]).

VALVES FOR HP AND HR HYDRAULIC MOTORS

DUAL VALVE KPDHR

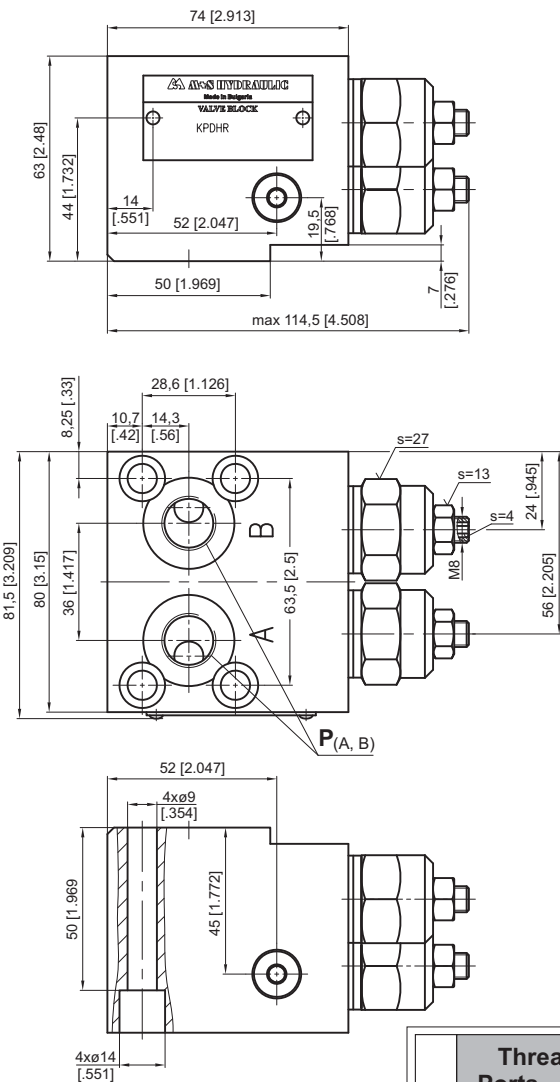

	Thread Ports - P _(A,B)
-	G3/8
M	M18x1,5
A	3/4-16 UNF O-ring

VALVES FOR RK HYDRAULIC MOTORS

DUAL VALVE KPDRK

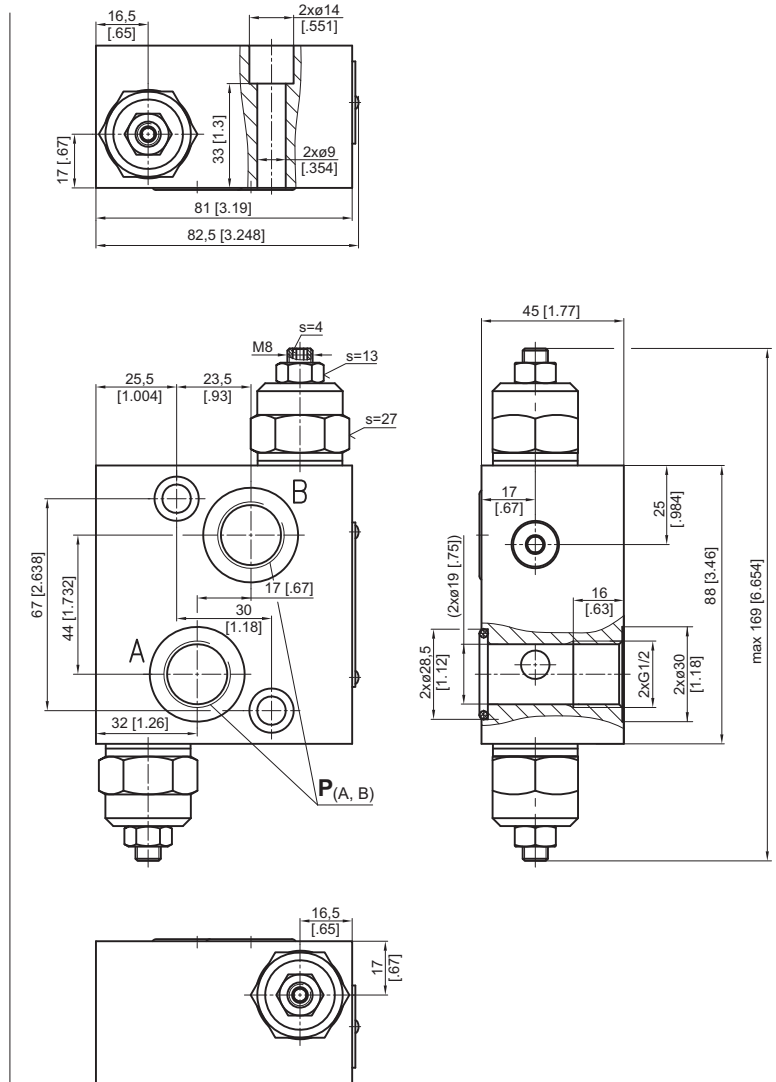

	Thread Ports - P _(A,B)
-	G1/2

Note : KPDHR Blocks are installed directly on HP and HR Motors with four screws M8x60 - 8.8 DIN 912.
 KPDRK Blocks are installed directly on RK Motors with two screws M8x45 - 8.8 DIN 912.
 Tightening torque 2,0^{+0,5} daNm [177⁺⁴⁵ lb-in].

ORDER CODE - OVERCENTER VALVES WITH BRAKE CONTROL

	1	2	3	4	5	6	7
K P B		-	/	/			

Pos.1 - Housing Type

- R** - Valve block for MP, MR and MH Motors
- S** - Valve block for MS Motors
- W** - Valve block for RW and HW Motors
- T** - Valve block for MT Motors
- V** - Valve block for MV Motors
- HR** - Valve block for HP and HR Motors

Pos.2 - Pressure Range, bar [PSI]

- 250** - 70÷250 [1015÷3625], Std Setting 250 bar@5 lpm

Pos.3 - Pilot Ratio

- 1** - 4,25:1

Pos.4 - Number of Valves

- D** - Two Valves - Dual
- E** - One Valve - Single (for R and S only)
- AE** - One Valve on line A - Single (for T, V and W only)
- BE** - One Valve on line B - Single (for T, V and W only)

Pos.5 - Threaded Ports

- omit - BSPP thread - ISO 228
- M** - Metric thread - ISO 262
- A** - Unified inch screw threads ANSI B 1.1 - 1982

Pos.6 - Option [Paint]**

- omit - no Paint
- P** - Painted
- PC** - Corrosion Protected Paint

Pos.7 - Design Series

- omit - Factory specified

Notes: * Color at customer's request.

ORDER CODE - SWITCH VALVES

	1	2	3	4
K P W				

Pos.1 - Housing Type

- R** - Valve block for MP, MR and MH Motors
- S** - Valve block for MS Motors
- T** - Valve block for MT Motors
- V** - Valve block for MV Motors

Pos.2 - Threaded Ports

- omit - BSPP thread - ISO 228
- M** - Metric thread - ISO 262
- A** - Unified inch screw threads ANSI B 1.1 - 1982

Pos.3 - Option [Paint]**

- omit - no Paint
- P** - Painted
- PC** - Corrosion Protected Paint

Pos.4 - Design Series

- omit - Factory specified

Notes: * Color at customer's request.

ORDER CODE - CROSSOVER RELIEF VALVE

	1	2	3	4	5	6
K P				/		

Pos.1 - Number of Valves

- D** - Two Valves - Dual
- E** - One Valve - Single (for R and S only)
- EA** - One Valve on line A - Single (for T, V and W only)
- EB** - One Valve on line B - Single (for T, V and W only)

Pos.2 - Housing Type

- R** - Valve block for MP, MR and MH Motors
- S** - Valve block for MS Motors
- W** - Valve block for RW and HW Motors
- T** - Valve block for MT Motors
- V** - Valve block for MV Motors

Pos.3 - Pressure Range, bar [PSI]

- 100*** - 30÷100 [435÷1450], Std Setting 100 bar@5 lpm
- 210*** - 50÷210 [725÷3050], Std Setting 210 bar@5 lpm
- 300*** - 80÷300 [1160÷4350], Std Setting 250 bar@5 lpm
- 210**** - 80÷210 [1160÷3050], Std Setting 210 bar@5 lpm
- 100***** - 10÷100 [145÷1450], Std Setting 100 bar@5 lpm
- 250***** - 20÷250 [290÷3625], Std Setting 250 bar@5 lpm

Pos.4 - Threaded Ports

- omit - BSPP thread - ISO 228
- M** - Metric thread - ISO 262
- A** - Unified inch screw threads ANSI B 1.1 - 1982

Pos.5 - Option [Paint]****

- omit - no Paint
- P** - Painted
- PC** - Corrosion Protected Paint

Pos.6 - Design Series

- omit - Factory specified

Notes: * Useful for types R and S only.
 ** Useful for types T only.
 *** Useful for types V only.
 **** Color at customer's request.

The Valve Blocks are mangano phosphatized as standard.

ORDER CODE - CROSSOVER RELIEF VALVE

	1	2	3	4	5	6
KP				/		

Pos.1 - Number of Valves

D - Two Valves - Dual

Pos.2 - Housing Type

HR - Valve block for HR Motors

RK - Valve block for RK and GHL Motors

Pos.3 - Pressure Range, bar [PSI]

40 - 10÷ 40 [145÷ 580], Std Setting 100 bar@5 lpm

100 - 30÷100 [435÷1450], Std Setting 100 bar@5 lpm

250 - 80÷250 [1160÷3625], Std Setting 250 bar@5 lpm

Pos.4 - Threaded Ports

omit - BSPP thread - ISO 228

M - Metric thread - ISO 262

A - Unified inch screw threads ANSI B 1.1 - 1982

Pos.5 - Option [Paint]*

omit - no Paint

P - Painted

PC - Corrosion Protected Paint

Pos.6 - Design Series

omit - Factory specified

Notes: * Color at customer's request.

The Valve Blocks are mangano phosphatized as standard.

MOTOR-BRAKE SPECIAL FEATURES

Special Feature Description	Order Code	Motor type				
		B/MR	MT/B	MTM/B	SW	TW
Low Leakage	LL	○	-	○	-	-
Low Speed Valving	LSV	○	-	○	-	-
Free Running	FR	-	-	○		-
Reverse Rotation	R	○	○	○	-	-
Paint*	P	○	○	○	○	○
Corrosion Protected Paint*	PC	○	○	○	○	○
Special Paint**	PS	○	○	○	○	○
	PCS					
Check Valves		S	S	-	S	S

O	Optional
-	Not applicable
S	Standard

* Colour at customer's request.

** Non painted feeding surfaces, colour at customer's request.

APPLICATION CALCULATION

VEHICLE DRIVE CALCULATIONS

1. Motor speed: n, RPM

$$n = \frac{2,65 \times v_{km} \times i}{R_m} \quad n = \frac{168 \times v_{mi} \times i}{R_{in}}$$

v_{km} - vehicle speed, km/h;

v_{mi} - vehicle speed, mil/h;

R_m - wheel rolling radius, m;

R_{in} - wheel rolling radius, in;

i - gear ratio between motor and wheels.

If no gearbox, use $i=1$.

2. Rolling resistance: RR, daN [lbs]

The resistance force resulted in wheels contact with different surfaces:

$$RR = G \times \rho$$

G - total weight loaded on vehicle, daN [lbs];

ρ - rolling resistance coefficient (Table 1).

Table 1

Rolling resistance coefficient In case of rubber tire rolling on different surfaces	
Surface	ρ
Concrete- faultless	0.010
Concrete- good	0.015
Concrete- bad	0.020
Asphalt- faultless	0.012
Asphalt- good	0.017
Asphalt- bad	0.022
Macadam- faultless	0.015
Macadam- good	0.022
Macadam- bad	0.037
Snow- 5 cm	0.025
Snow- 10 cm	0.037
Polluted covering- smooth	0.025
Polluted covering- sandy	0.040
Mud	0.037÷0.150
Sand- Gravel	0.060÷0.150
Sand- loose	0.160÷0.300

3. Grade resistance: GR, daN [lbs]

$$GR = G \times (\sin \alpha + \rho \times \cos \alpha)$$

α - gradient negotiation angle (Table 2)

Table 2

Grade %	α Degrees	Grade %	α Degrees
1%	0° 35'	12%	6° 5'
2%	1° 9'	15%	8° 31'
5%	2° 51'	20%	11° 19'
6%	3° 26'	25%	14° 3'
8%	4° 35'	32%	18°
10%	5° 43'	60%	31°

4. Acceleration force: FA, daN [lbs]

Force FA necessary for acceleration from 0 to maximum speed v and time t can be calculated with a formula:

$$FA = \frac{v_{km} \times G}{3,6 \times t}, [daN] \quad FA = \frac{v_{mi} \times G}{22 \times t}, [lbs];$$

FA - acceleration force, daN [lbs];

t - time, [s].

5. Tractive effort: DP, daN [lbs]

Tractive effort DP is the additional force of trailer. This value will be established as follows:

-acc.to constructor's assessment;

-as calculating forces in items 2, 3 and 4 of trailer; the calculated sum corresponds to the tractive effort requested.

6. Total tractive effort: TE, daN [lbs]

Total tractive effort TE is total effort necessary for vehicle motion; that the sum of forces calculated in items from 2 to 5 and increased with 10 % because of air resistance.

$$TE = 1,1 \times (RR + GR + FA + DP)$$

RR - force acquired to overcome the rolling resistance;

GR - force acquired to slope upwards;

FA - force acquired to accelerate (acceleration force);

DP - additional tractive effort (trailer).

7. Motor Torque moment: M, daNm [lb-in]

Necessary torque moment for every hydraulic motor:

$$M = \frac{TE \times R_m [R_{in}]}{N \times i \times \eta_m}$$

N - motor numbers;

η_m - mechanical gear efficiency (if it is available).

8. Cohesion between tire and road covering: M_w, daNm [lb-in]

$$M_w = \frac{G_w \times f \times R_m [R_{in}]}{i \times \eta_m}$$

To avoid wheel slipping, the following condition should be observed $M_w > M$

f - frictional factor;

G_w - total weight over the wheels, daN [lbs].

Table 3

Surface	Frictional factor f
Steel on steel	0.15 ÷ 0.20
Rubber tire on polluted surface	0.5 ÷ 0.7
Rubber tire on asphalt	0.8 ÷ 1.0
Rubber tire on concrete	0.8 ÷ 1.0
Rubber tire on grass	0.4

9.Radial motor loading: P_{rad} , daN [lbs]

When motor is used for vehicle motion with wheels mounted directly on motor shaft, the total radial loading of motor shaft P_{rad} is a sum of motion force and weight force acting on one wheel.

- G_w - Weight held by wheel;
- P_{rad} - Total radial loading of motor shaft;
- M/R - Motion force.

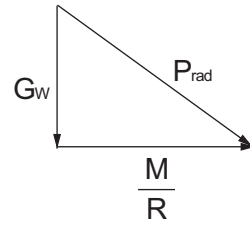

$$P_{rad} = \sqrt{G_w^2 + \left(\frac{M}{R}\right)^2}$$

In accordance with calculated loadings the suitable motor from the catalogue is selected.

DRAINAGE SPACE AND DRAINAGE PRESSURE

Advantages in oil drainage from drain space: Cleaning; Cooling and Seal lifetime prolonging.

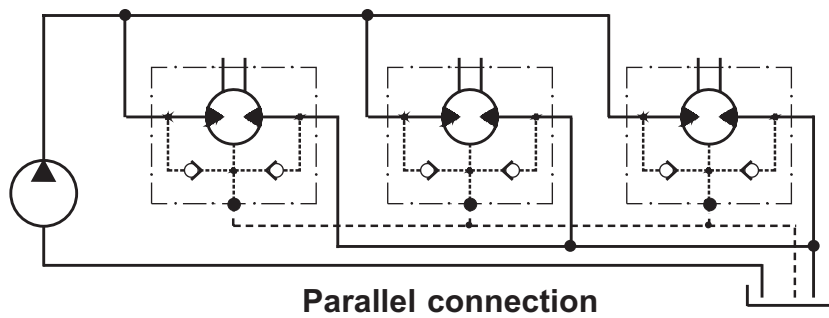
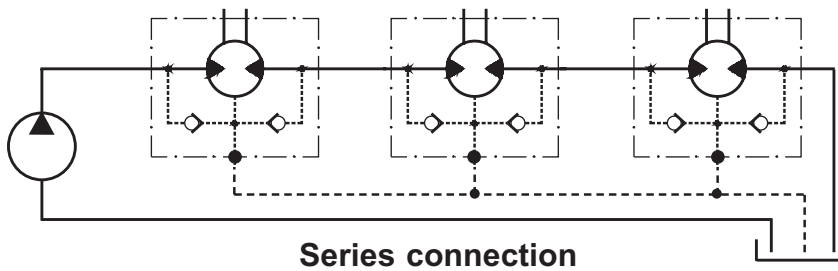

WARRANTY

M+S Hydraulic warrants, that its products, supplied directly to original equipment manufacturer, authorized distributor or other customer, will be free of defects in material or workmanship at the time of shipment from M+S Hydraulic and will conform to the products technical documentation (drawings and specifications) under sale agreement with Buyer.

This warranty will apply only to defects appearing within applicable Warranty period, mentioned below. If Buyer notifies M+S Hydraulic within the Warranty period about any such defects, M+S, at its sole option will replace or repair the defective products or their parts found by M+S Hydraulic to be defective in material or workmanship.

THE FOREGOING LIMITED WARRANTY IS AVAILABLE ONLY IF "M+S HYDRAULIC" IS PROMPTLY NOTIFIED IN WRITTEN OF THE ALLEGED DEFECT AND DOES NOT COVER FAILURE TO FUNCTION CAUSED BY DAMAGE TO THE PRODUCT, IMPROPER INSTALLATION, UNREASONABLE USE OR ABUSE OF THE PRODUCT, FAILURE TO PROVIDE OR USE OF IMPROPER MAINTENANCE OR USUAL, DEGRADATION OF THE PRODUCT DUE TO PHYSICAL ENVIRONMENTS OF AN USUAL NATURE. THE FOREGOING REMEDIES ARE THE SOLE AND EXCLUSIVE REMEDIES AVAILABLE TO CUSTOMER. To facilitate the inspection, M+S Hydraulic may require return of the product/part, which Buyer claims to be defective.

M+S Hydraulic shall not be liable for labor costs or any other expenses incurred during the disassembling or reinstalling of the product/part.

In case the claimed products are returned to M+S Hydraulic in bad condition: dirty, disassembled, with damaged or missing parts during transportation, the warranty will be considered as not applicable and the products will not be liable to repair.

Warranty periods

New products: The Warranty period is limited to 24 consecutive months (2 years) from the date of production of the product.

Repaired products: If the product is repaired in M+S Hydraulic during its warranty period, the warranty period of the repaired item shall continue for the balance of original Warranty period or for a period equal to 50% of the original new product Warranty period, whichever is later.

Spare parts: The Warranty period for Spare parts is 12 consecutive months (1 year) from the dispatch date of such parts from M+S Hydraulic.

LIMITATION OF LIABILITY M+S Hydraulic's liability for claim of any kind, for loss or damage arising out of, connected with or resulting from an order, or from the performance or branch thereof, or from the design, manufacture, sale delivery, operation or use of any of its products shall be limited to, at M+S 's sole option, replacement, repair of any defective product or the issuance of a credit to Customer against any future purchases. Cash refunds will not be made under any circumstances and Customer will not be entitled to recover any damages of any kind against M+S Hydraulic, including but not limited to incidental or consequential damages, whether direct or indirect, known or unknown, foreseen or unforeseen.



68, Kozloduy St. 6100 Kazanlak, BULGARIA

Tel.: +359 431 64271, + 359 431 65167, Fax: +359 431 64114

E-mail: msh@ms-hydraulic.com Web: www.ms-hydraulic.com



Via Mentana 20, Nichelino (TO), ITALY

Tel: +39 011 6800838, Fax: +39 011 6807782

E-mail: commerciale@oleotecno.it

Web: www.ms-hydraulic.it, www.oleotecno.it

componenti oleodinamici